

# CERN COURIER

International journal of high energy physics

VOLUME 37

10

DECEMBER 1997



# 21<sup>st</sup> Century's TDCs

To meet the requirements of the next generation HEP Experiments, two leading European Physics Research Institutes have developed two ASIC

**Multihit Time-to-Digital Converters**  
in VLSI technology.

By integrating them in two single-width, 6U VME modules we have created two modular TDCs featuring an

**unprecedented density** and the **lowest price per channel** achieved to this date.

They are available now to allow today's experiments to take advantage of **next century's' technology.**

Type*	V667	V673A	V767	V693
Width	1 slot	1 slot	1 slot	1 slot
Channels	64	64	128	128
Bits	21	16	20	16
LSB	780 psec**	1 nsec	780 psec**	1 nsec
DPR	10 nsec	5 nsec	10 nsec	5 nsec
Conv. Time	Nil	Nil	Nil	Nil
Output Buffer	2KWords	4 events 6KWords	32KWords	4 events 12KWords

\*VME 6U Units    \*\* 520 psec with speed graded ICs and 60 MHz Clock

The V667 and V767 are based on an IC developed at CERN by the ECP-MIC Group  
The V673A and V693 are based on an IC developed for the KLOE experiment by INFN-Roma

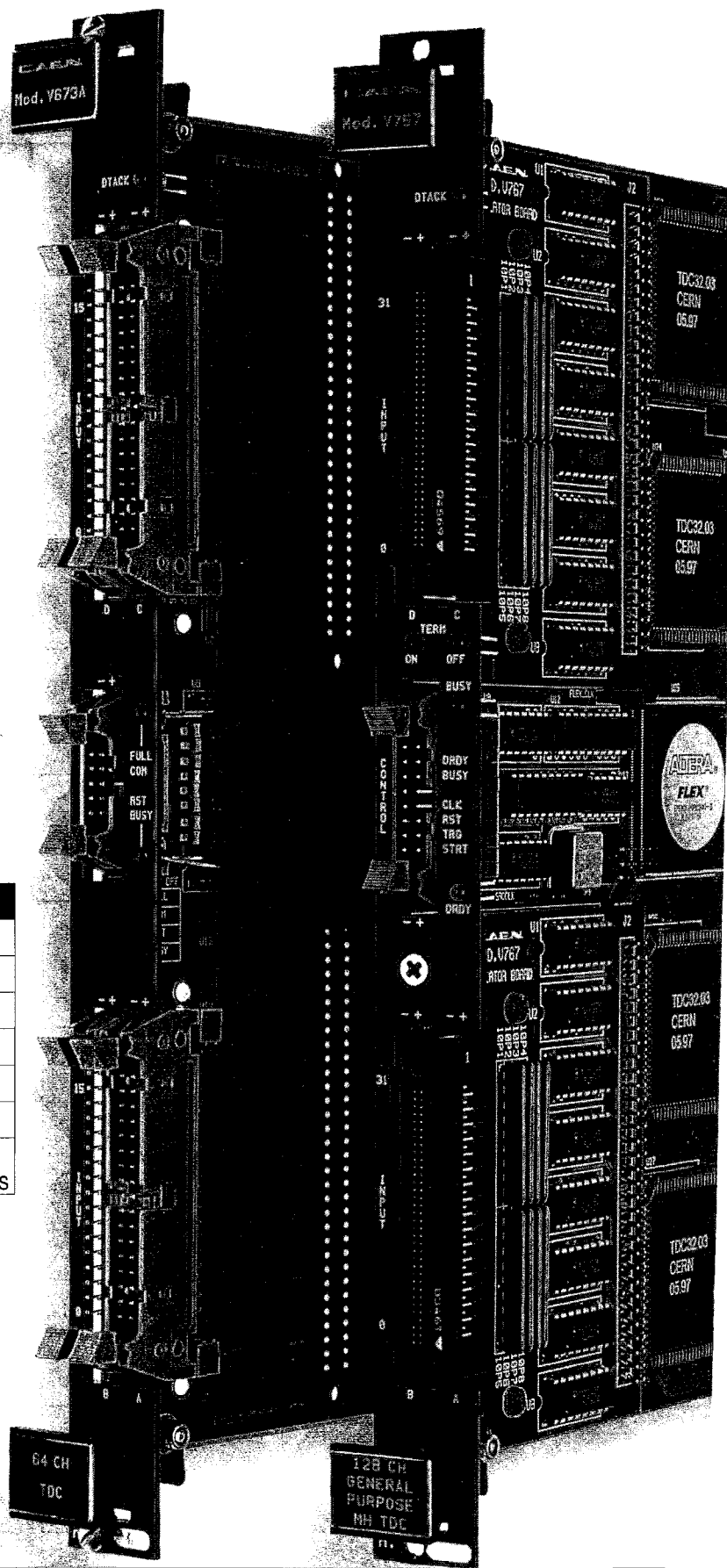

**CAEN**

COSTRUZIONI APPARECCHIATURE ELETTRONICHE NUCLEARI S.p.A.

Iscritta all'Albo dei Laboratori di ricerca (Decr. Min. 25/3/90)

Via Vetraia, 11 - 55049 VIAREGGIO (ITALY) - Tel. (0584) 388398 - Fax (0584) 388959 - E-mail: info@caen.it - URL: http://www.caen.it

## Advertising enquiries

### Europe

Micheline Falciola  
Advertising Manager  
CERN  
CH-1211 Geneva 23, Switzerland  
Tel.: +41 (22) 767 4103  
Fax: +41 (22) 782 1906

### Rest of the world

Danielle Ford  
Advertising Manager, USA  
International Publishers Distributor  
820 Town Center Drive  
LANGHORNE PA 19047  
Tel.: (215) 750-2642  
Fax: (215) 750-6343

*Distributed to Member State governments, institutes and laboratories affiliated with CERN, and to their personnel.*

## General distribution

Jacques Dallemagne  
CERN, 1211 Geneva 23, Switzerland

In certain countries, to request copies or to make address changes contact :

### China

Chen Huaiwei  
Institute of High Energy Physics  
P.O. Box 918, Beijing,  
People's Republic of China

### Germany

Gabriela Heessel or Astrid Nagel  
DESY, Notkestr. 85, 22603 Hamburg 52

### Italy

Mrs. Pieri or Mrs. Montanari  
INFN, Casella Postale 56  
00044 Frascati, Roma

### United Kingdom

Su Lockley  
Rutherford Appleton Laboratory,  
Chilton, Didcot, Oxfordshire OX11 0QX

### USA/Canada

Janice Voss  
Creative Mailing Services  
P.O. Box 1147  
St. Charles, Illinois 60174  
Tel.: 630-377-1589 / Fax: 630-377-1569

CERN COURIER is published monthly except January and August in English and French editions. The views expressed in the Journal are not necessarily those of the CERN management.

Printed by: Drukkerij Lannoo nv  
8700 Tielt, Belgium

Published by:

European Laboratory for Particle Physics  
CERN, 1211 Geneva 23, Switzerland  
tel.: +41 (22) 767 61 11,  
telex: 419 000 CERN CH,  
telefax: +41 (22) 767 65 55

CERN COURIER only:  
tel. +41 (22) 767 41 03,  
telefax +41 (22) 782 19 06

USA: Controlled Circulation  
Periodicals postage paid at St. Charles,  
Illinois

ISSN 0304-288X

Volume 37

No. 10

December 1997

## Covering current developments in high energy physics and related fields worldwide

Editor: Gordon Fraser  
CERN.COURIER@ CERN.CH

Production and Advertisements:  
Micheline Falciola  
Micheline.Falciola@cern.ch

Advisory Board: E.J.N. Wilson (Chairman), E. Lillestol,  
M. Neubert, D. Treille; with L. Foà,  
J. Ferguson

World Wide Web <http://www.cern.ch/CERN/Courier/>

1

Muon colliders move nearer  
*Steve Geer surveys a new machine scenario*

3

Making history, part 3  
*Luigi Di Lella with the latest volume of CERN's official history*

8

Superconducting success  
*CERN's LEP electron-positron collider passes another milestone*

### Around the Laboratories

12

FRASCATI: DAFNE complete  
*First electrons in new Italian machine*

13

NOVOSIBIRSK: VEPP-2M phi-nesses  
*Siberian electron-positron harvest*

14

PROTVINO: Hybrid mesons  
*Exotic quark-gluon states*

15

MUNICH: First beam in superconducting separated orbit  
cyclotron  
*Triton debut*

16

NIKHEF: Two proton knock-out  
*Nuclear insights*

18

CERN: Computing school

19

HEIDELBERG: Debut of GENIUS  
*New detector proposed*

### Physics monitor

20

Cosmology below ground  
*Second part of report on Gran Sasso meeting*

25

Radiofrequency superconductivity  
*Biennial workshop*

28

### People and things



Cover photograph: Monica Dirac, daughter of famous physicist Paul Dirac (1902-84) unveils a plaque at the formal opening of Dirac House, the new headquarters of the UK Institute of Physics Publishing, Bristol. Dirac was born in Bristol (Photo Grant Watson).

# CES PRESENTS:

After the CPU... The Interconnection...

## PVIC: a 100 Mbytes/s PCI/PCI Transparent Connection

Our PowerPC computing cores provide the best real-time performance for DAQ and accelerator control. The PVIC extends this performance towards:

- other processors within the same crate,
- other processors in distant crates,
- PCI equipped workstations

- transparent connection: no latency, reduces SW overhead
- 15 nodes on up to 200 meters
- integrated DMA CTL supporting linked lists transactions with minimum CPU load
- supports byte, word, long-word transactions
- broadcast & multicast operation
- interrupt dispatching, mailboxes, FIFOs, mirrored memory, efficient multiprocessor communication with global semaphores
- 3 different transmission media connecting 3 different types of platforms (PCI, PMC, VME)
- library for CES bundled packages

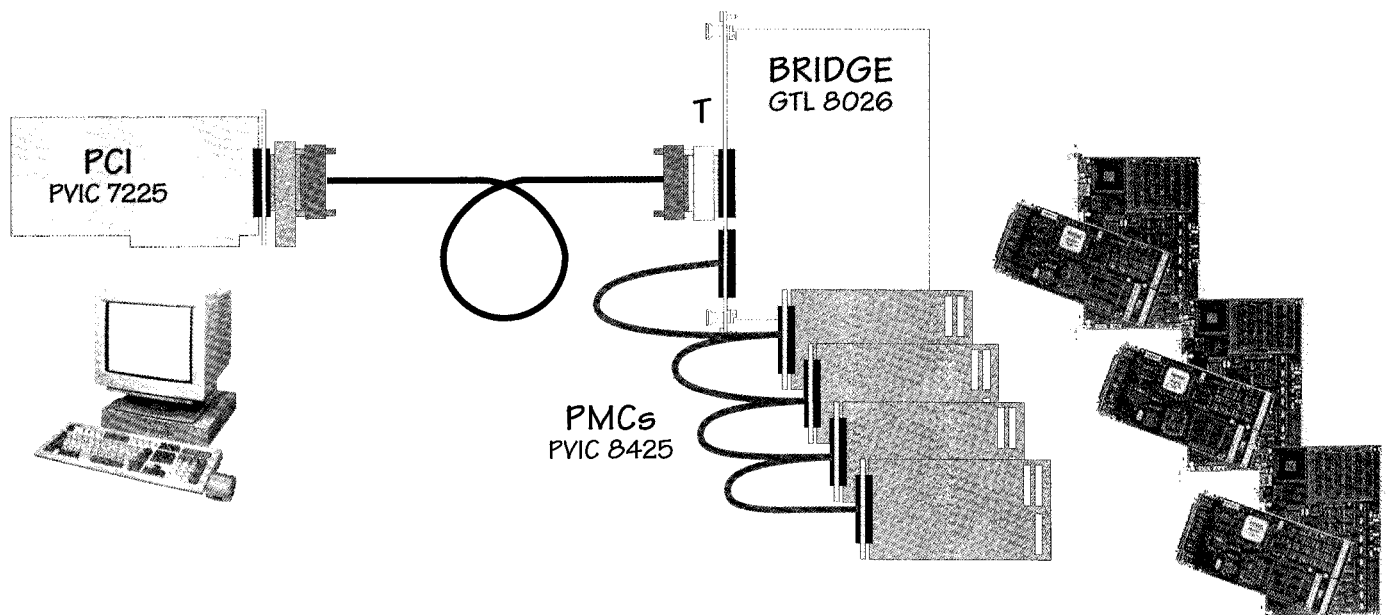

Example of connection with the first members of the PVIC family

The PVIC implements a transparent mapping mechanism between PCI bus segments in much the same way than VIC bus offers transparent mapping between different VME crates. It can connect PCI based processor boards to each other and to PCI based desktop workstations

on three different distance scales: below 1 meter (e.g. within a VME crate, flat cable, GTL+), up to 20 meters (PECL differential copper connection), and up to 200 meters (850 nm multimode fiber). Up to 15 nodes can be connected to form a single PVIC system.



*Your Real-Time Partner*



For any additional information about this product or our complete PowerPC, PMC, Connections, VME, CAMAC and FASTBUS line, do not hesitate to contact us.

CES Geneva, Switzerland Tel: +41-22 792 57 45 Fax: +41-22 792 57 48 EMail: ces@lancy.ces.ch  
CES.D Germany Tel: +49-60 55 4023 Fax: +49-60 55 82 210  
CES Creative Electronic Systems SA, 70 Route du Pont-Butin, CH-1213 Petit-Lancy 1, Switzerland  
Internet: <http://www.ces.ch>



# Muon colliders move nearer

Figure 1 - Comparison of the sizes of various futuristic hadron-hadron and lepton-antilepton colliders. Shown are footprints for the First Muon Collider (FMC), Next Muon Collider (NMC), Next Linear Collider (NLC), and Very Large Hadron Collider (VLHC). These are compared with the footprint of the 27 kilometre-circumference LHC at CERN, and the existing Fermilab site.

Our present theoretical prejudice is that new physics "beyond the Standard Model" will emerge in quark-antiquark and lepton-antilepton (electron or muon) collisions at or approaching the TeV energy scale. To fully explore the TeV scale will require at least one multi-TeV hadron-hadron collider to make a broad search for new physics, and one or more TeV scale lepton-antilepton colliders to make precision measurements of new phenomena.

The next big step forward in advancing the hadron-hadron collider energy frontier will be provided by CERN's Large Hadron Collider (LHC), a proton-proton collider with a centre-of-mass energy of 14 TeV due to come into operation in 2005.

The route towards TeV scale lepton-antilepton colliders is less clear. The lepton-antilepton colliders built so far have been electron-positron-colliders like the Large Electron Positron collider (LEP) at CERN and the Linear Collider (SLC) at SLAC.

However, electrons are very light and like to radiate away their energy when they are accelerated. In a circular ring like LEP the energy lost per revolution in keV is  $88.5 E^4/r$  where the electron energy  $E$  is in GeV, and the radius of the orbit  $r$  is in metres. Hence, the energy loss grows rapidly as  $E$  increases. This limits the centre-of-mass energy that would be achievable in a LEP-like collider.

The problem can be reduced by building a linear machine like the SLC, but technical challenges still appear to make it very difficult in practice to approach and go beyond the TeV energy scale.

For a lepton with mass  $m$ , the energy losses per revolution in a circular ring are inversely

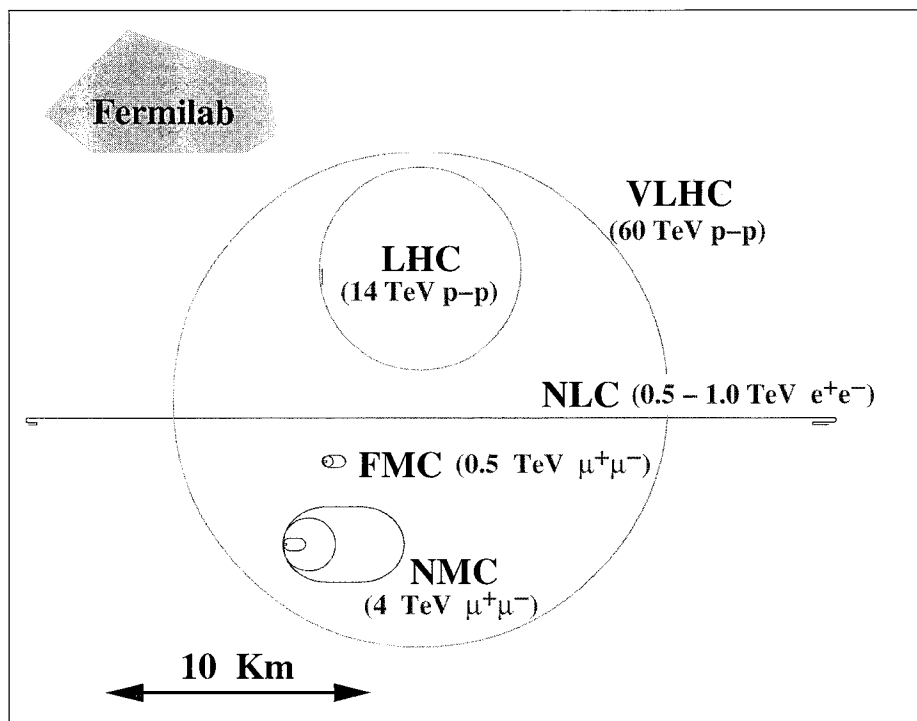

proportional to  $m^4$ . Hence, the energy loss problem can be solved by using heavy leptons. In practice this means using muons, which have a mass 207 times that of the electron. The resulting enormous reduction in radiative losses enables higher energies to be reached, and smaller collider rings to be used. Estimated sizes of the accelerator complexes required for 0.5 TeV and 4 TeV muon colliders are compared with the sizes of other futuristic colliders in Figure 1.

At least two generations of muon colliders would fit on existing laboratory sites. Although the cost of building a muon collider is still unknown, it would be relatively small and fit within an existing laboratory, so muon collider proponents expect the cost to be cheaper than alternative futuristic machines.

Muon colliders also offer some physics advantages. The small radiative losses give a very small

beam energy spread, allowing very precise measurements of the masses and widths of any new resonant states scanned by the collider. In addition, since the cross-section for producing a Higgs-like scalar particle in lepton-antilepton annihilation is proportional to  $m^2$  this extremely important process could be studied at a muon collider but not at an electron-positron collider.

The muon collider idea dates back to Tinlow (1960). There are significant challenges in designing an accelerator complex that can make, accelerate, and collide positive and negative muon bunches before nearly all of the muons have decayed, which they do with a rest lifetime of 2.2 microseconds. However, at the 1995 Sausalito workshop it was realized that, with modern ideas and technology, it may be feasible to make muon bunches containing a few times  $10^{12}$  muons and, before

Figure 2: Schematic of the accelerator complex needed to produce, cool, and accelerate muons for a high energy muon collider.

more than about half of the muons have decayed, compress the phase space occupied by the muons by a factor of  $10^5 - 10^6$  and accelerate the resulting intense muon bunch up to the multi-TeV energy scale.

It was also realized that with careful design of the collider ring and shielding it may be possible to reduce to acceptable levels the backgrounds within the detector that arise from the very large flux of electrons produced in muon decays. These realizations led to an intense activity involving almost 100 accelerator and particle physicists, which resulted in the muon collider feasibility study report prepared for the 1996 Snowmass workshop.

One year after Snowmass, encouraged by further progress in developing the muon collider concept together with the growing interest and involvement of the high energy physics community, the "Muon Collider Collaboration" became a formal entity in May. The collaboration is receiving strong support and participation from 3 US laboratories (Brookhaven, Fermilab, and Berkeley) and a growing number of university groups. The goal of the collaboration is to complete within a few years the R&D needed to determine whether a Muon Collider is technically feasible, and if it is, to design the First Muon Collider.

Figure 2 shows a schematic of a muon collider accelerator complex. In the example illustrated, proton bunches containing  $5 \times 10^{13}$  particles are accelerated to energies of 16 GeV. The protons interact in a target to produce approximately  $3 \times 10^{13}$  charged pions of each sign. These pions are produced with only a very limited component of momentum transverse to the incident proton

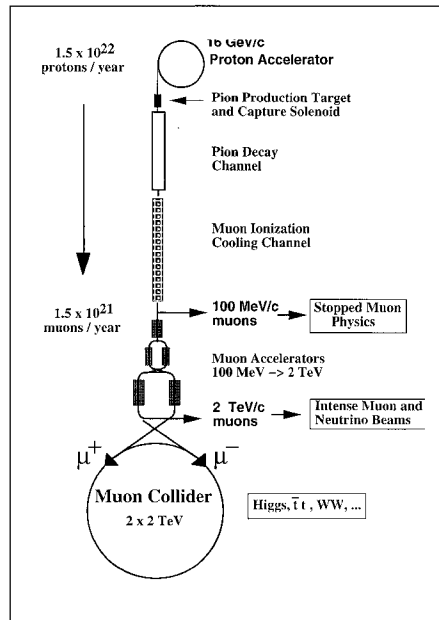

direction, and can be confined within a beam channel using, for example, a 20 Tesla co-axial solenoid with an inner radius of 7.5 cm.

To collect as many particles as possible within a useful energy interval, radiofrequency (rf) cavities are used to accelerate the lower energy particles and decelerate the higher energy ones. Muons are produced by allowing the pions to decay into a muon plus neutrino, which they do with a rest lifetime of  $2.6 \times 10^{-8}$  s.

For example, at the end of a 20 m long decay channel consisting of a 7 Tesla solenoid with a radius of 25 cm each incident proton results in about 0.2 muons of each charge. With two proton bunches every accelerator cycle, the first used to make and collect positive muons and the second to make and collect negative muons, there are about  $10^{13}$  muons of each charge available at the end of the decay channel per accelerator cycle.

If the proton accelerator is cycling at 15 Hz, in an operational year ( $10^7$

secs) about  $1.5 \times 10^{21}$  positive and negative muons would have been produced and collected.

The muons exiting the decay channel populate a very diffuse six-dimensional phase space (the volume occupied by the beam times the volume in momentum space). The next step in the muon collider complex is to "cool" the muon bunch, i.e. to turn the diffuse muon cloud into a very "bright" bunch with small longitudinal and transverse dimensions, suitable for accelerating and injecting into a collider. The cooling must be done rapidly compared to the muon lifetime, and conventional stochastic and electron cooling techniques take too long.

The new technique proposed for cooling muons is called ionization cooling, and is illustrated in Figure 3. The idea is that the muons traverse some material in which they lose both longitudinal and transverse momentum by ionization losses ( $dE/dx$ ). The longitudinal momentum is then replaced using an rf accelerating cavity, and the process is repeated many times until there is a large reduction in the transverse phase space occupied by the muons.

The energy spread within the muon beam can also be reduced with ionization cooling by using a wedge-shaped absorber in a region of dispersion (where the transverse position is momentum dependent). The wedge is arranged so that the higher energy particles pass through more material than lower energy ones. Initial calculations suggest that the phase space occupied by the initial muon bunches can be reduced by a factor of  $10^5 - 10^6$  before multiple coulomb scattering limits further reduction. At the end of the ionization cooling channel each muon bunch is expected to contain

# Making history, part 3

Now published is the third volume of the *History of CERN*, from North Holland/Elsevier Science\*. Spanning detailed developments from 1949 to the late 1970s, they contain a wealth of information, together making up 2200 pages. As well as being an in-depth review of Volume III, this critical appraisal by CERN's Luigi Di Lella provides a succinct overview of a vital period in CERN's history. \*(The three volumes are available separately, or as a set: ISBN 0 444 82656, price \$560.75)

*History of CERN, Volume III*, edited by J. Krige, published by North-Holland Elsevier Science (ISBN 0 444 89655 4), 674 pages, \$234.50

This volume describes the evolution of CERN and its technical and scientific achievements from the mid-1960s to the birth of the proton-antiproton collider project. This was a period of rapid expansion of the laboratory, both in terms of footprint and of staff, first with the construction of the Intersecting Storage Rings (ISR) in the late 60s, and then with the construction of the SPS in the 70s. During the same time the community of physicists using CERN expanded enormously, because of the increased concentration of experimental facilities at CERN and of the simultaneous, gradual phasing out of the existing accelerators in most national laboratories.

The volume is in three parts. The first, written by science historians (J. Krige, D. Pestre and A. Russo) describes the large projects with their political, managerial and technical problems. It details the complex relationship between the laboratory and its outside users, and the

about  $5 \times 10^{12}$  muons with a momentum of order 100 MeV/c.

Rapid acceleration to the collider beam energy can be achieved in either a recirculating linear accelerator and/or a rapid cycling synchrotron. Positive and negative muon bunches are then injected in opposite directions into a collider storage ring and brought into collision at the interaction point.

The bunches circulate and collide for many revolutions before decay has depleted the beam intensities. For example, in a collider with 2 TeV muon beams (4 TeV collision energy) and a circumference of 8 km, the muon bunches would make about 1000 revolutions before being "dumped". New muon bunches would be injected into the collider about 15 times a second.

There are many interesting and challenging problems that need to be resolved before the feasibility of building a muon collider can be demonstrated. For example, (i) the very intense proton bunches will destroy a solid target, necessitating the development of a liquid metal jet target, and (ii) to attain the desired ionization cooling factor, current designs require the development of rf cavities with thin beryllium windows operating at liquid nitrogen temperatures in high solenoidal fields, and also the development of long liquid lithium lenses to provide very strong radial focusing for the final cooling stages.

Despite these and many other technical challenges, no "show stoppers" have yet been identified, and there is growing enthusiasm amongst the particle and accelerator physics communities to find out whether a muon collider is really feasible. If the answer is yes, then the first muon collider would probably be a "low energy" machine and might be, for example, a Higgs boson "factory" if a Higgs-like boson exists with a mass in the 100 - 500 GeV range.

Perhaps at last we have an answer to the famous question I.I. Rabi asked after the discovery of the muon: "Who ordered that?". The answer must be "High-energy lepton-antilepton collider enthusiasts".

More information about muon collider R&D can be obtained at the following web sites: [http://www.fnal.gov/projects/muon\\_collider/](http://www.fnal.gov/projects/muon_collider/) and [http://www.cap.bnl.gov/mumu/mu\\_home\\_page.html](http://www.cap.bnl.gov/mumu/mu_home_page.html), or from the spokesperson for the muon collider collaboration (R. Palmer). Information about ionization cooling R&D can be obtained from S. Geer (spokesperson), and information about the muon production R&D program can be obtained from K. McDonald and R. Weggel (Spokespeople).

by Steve Geer (Fermilab)

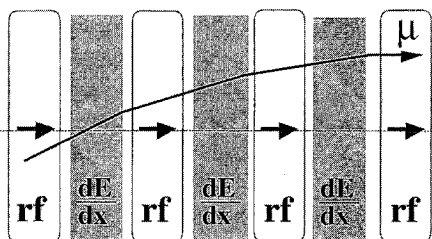
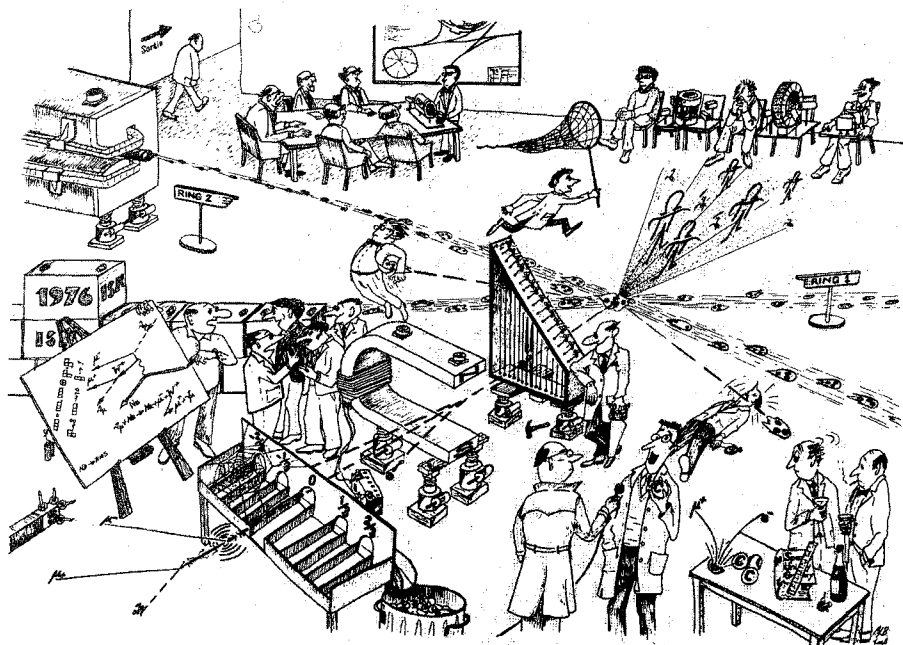

Figure 3: Schematic illustrating ionization cooling. Muons pass through absorbers (labelled  $dE/dx$ ) in which they lose momentum by ionization losses. The longitudinal component of the momentum is replaced by rf cavities providing acceleration in the direction of the arrows.

The operation of CERN's Intersecting Storage Rings (ISR) from 1971-84 marked a vital period in CERN's evolution. This detail-packed cartoon by Phil Bryant gives some idea of the physics preoccupations of 1977.



governments of the Member States which provide the financial resources. Its seven chapters cover five main subjects.

The first subject is the two big bubble chambers, Gargamelle and BEBC, the first example of large detectors used as general facilities and whose construction was decided by international committees (in the case of BEBC, this decision included an agreement between CERN, France and Germany to share its cost).

The second subject (Chapter 3) is the difficult decision to construct a 300 GeV proton synchrotron. This machine was originally supposed to be built in another site somewhere in Europe, chosen from sites proposed by CERN Member States. The sequence of events that took place between 1967 and the final approval by Council to build the SPS in a site adjacent to the existing CERN laboratory is particularly interesting because it demonstrates the close relationship between politics and science when big money is involved.

The first important event was the initial strong criticism (mainly by a German committee) of the CERN design (a scaled-up version of the PS), judged to be too conservative and costly compared with Bob Wilson's design for Fermilab's Main Ring and requiring that the design be rethought. A second important event was the British refusal to participate in the project, perhaps a reaction to General de Gaulle's veto of the entry of the UK in the Common Market, followed by the appointment of John Adams as Project Director at the end of 1968. One year later, with some downgrading of the project (in particular, an energy reduction from 300 to 200 GeV), a consensus seemed to be very close when the German government declared in a press release that their participation in the project would be reconsidered, should the German site not be chosen. This seemed to be the end of the project until John Adams intelligently proposed building the SPS at CERN, using a large part of existing infrastructure and greatly

reducing costs.

The lesson, whose net effect was a three-year delay in the first operation of the SPS, is perhaps that new, large accelerators should use as much as possible existing infrastructure and therefore be built next to existing laboratories. One may wonder whether the US SSC project would still be alive had it been decided to build it next to Fermilab rather than in Texas.

The third subject, discussed in Chapter 4, describes the construction and operation of the Intersecting Storage Rings (ISR) and reviews its physics programme. Much has been said and written about the ISR, generally considered as a great technological success but with disappointing physics results. This book does not modify this view. More precisely, one can feel the guilt complex that CERN developed after 1974 for missing the J/psi and, later, the upsilon. This appears very clearly in the little emphasis given to real ISR discoveries in comparison with the many pages discussing reasons for having missed discoveries.

In my opinion, the ISR discovery of copious production of high transverse momentum particles, many orders of magnitude greater than expected, has not received the recognition it deserves. Such a discovery was the first evidence for the existence of point-like strongly interacting proton constituents, to be identified later with quarks and gluons (the famous electron-nucleon deep inelastic scattering experiment at SLAC had demonstrated the existence of electrically charged, point-like proton constituents but had provided no information on their strong interaction behaviour). That discovery changed the study of hadron collisions at high energies.

Other important ISR discoveries are



*CERN's bold decision to embark on its antiproton project changed the course of 20th century science history. In July 1980, CERN's Antiproton Accumulator, the heart of the project, supplied its first beams. In the foreground, admiring the first results of their work, are key Antiproton Accumulator personalities (right to left) Simon van der Meer,*

*Eifion Jones and Roy Billinge. For his invention of the stochastic cooling technique which opened the door to the use of controlled antiproton beams, van der Meer shared the 1984 Nobel Prize with Carlo Rubbia who masterminded the antiproton project and oversaw its historic 1983 discoveries. (Photo CERN 89.7.80)*

not even mentioned - the detection of prompt, single lepton production in 1974 and the observation in the late 70s that the transverse momentum of Drell-Yan lepton pairs increases with energy. The latter was evidence for gluon radiation by the incoming quarks while the former was the first hint for charmed particles decaying leptonically. One important discovery, described under the title "The last achievement" was the first observation of prompt photons at high transverse momentum. This was clear evidence for quark-gluon collisions, an important fact not even mentioned in this book.

On the missed discoveries of the  $J/\psi$  and  $\psi$  particles, the book gives the impression that the reason was mainly the initial lack of sophisticated, large acceptance ISR detectors. This, in my opinion, is wrong. In the case of the  $\psi$  the problem was simply the insufficient ISR luminosity (in the late 70s and early 80s less than 100  $\psi$  particles were observed per year in the large acceptance detectors).

The case of the  $J/\psi$  is quite different. When the ISR started operation in 1971, it extended enormously the available energy domain. Physicists were naturally prompted to search in unexplored territory. This, and the need for a trigger to record the few, potentially interesting events among the many thousands occurring every second, led the physicists to deliberately exclude the low mass region. The trigger problem is indeed discussed in this book. Because of similar trigger problems, the much celebrated UA1 and UA2 experiments at CERN's proton-antiproton collider were unable to detect the  $J/\psi$  and  $\psi$  particles in their electron-positron decay mode. Last but not least, there was



no theoretical guidance suggesting a new particle in the 3-4 GeV mass range. In conclusion, this chapter is very interesting but, in my opinion, it gives a picture of ISR physics which is far too negative and, in some cases, even unfair to those who did the experiments.

The fifth chapter of the first part of this book discusses the relationship between CERN and its 'visitors' in the 70s, with many points of friction resulting mostly from the fact that the user community had grown enormously and that users had to spend more time at CERN because of the increased complexity of equipment and the longer running time allocated to experiments. Hence they demanded more decision-making power and working conditions similar to those of CERN staff.

As the ECFA chairman wrote in 1975, users had been dreaming of a laboratory in which an outside group arrives unencumbered and sets up an experiment by drawing instruments from a pool, and is provided

with magnets by the experimental support team. This is obviously naive, given the complexity of detectors already in operation in the 70s (how can one support this view while at the same time criticizing the ISR detectors for having too small an angular coverage?).

As I was myself at that time involved in experiments in collaboration with groups of visitors, I do not remember feeling any visitors' discontent.

Chapters 6 and 7 deal with the history of the proton-antiproton project, following Carlo Rubbia's 1976 proposal to transform the new SPS into a collider and hunt the  $W$  and  $Z$  bosons. Chapter 6 describes the competition with Fermilab, the first cooling experiment using the magnet ring recycled from the muon  $g-2$  experiment, and the events that led to the historic decision to go ahead. The book gives the correct impression of the enormous risk taken by CERN management to provide CERN with a much needed discovery of historical importance,

*Georges Charpak alongside an early electronic detector in 1965. The development of electronic tracking detectors at CERN was dominated by his invention of the multiwire proportional chamber which revolutionized experimental particle physics and led on to other tracking devices such as the drift and time projection chambers.*

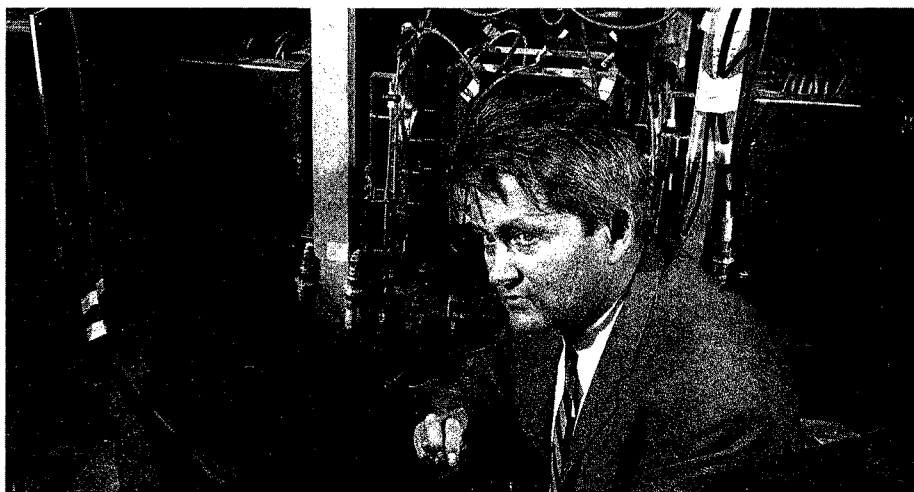

against widespread support for other solutions (such as the construction of a superconducting proton-proton collider in the ISR tunnel).

Chapter 7, dealing with the organization of an experimental collaboration using UA1 as an example, is mainly sociological and may be interesting for those not used to close international collaboration. (One point I found somewhat strange is the question whether building a detector is doing physics. Of course it is, but the author seems to reach this conclusion only after talking to experimentalists!)

The second part of the book (Physics Results) consists of three chapters written by physicists. The first subject (by J. Iliopoulos) describes the work of CERN's Theory Division from its creation in Copenhagen in the early 50s (when there was no building yet on the Meyrin site) until the mid 70s, contained in some 7000 published papers. It also gives an idea of mobility and innovation. The author attempts to excuse Theory Division for its lack of contributions to the Standard Model and for its failure to respond promptly to new discoveries during that period.

Not discussed is the relation be-

tween theorists and experimentalists. As I remember, this was almost totally non-existent in the 60s, as demonstrated by the remarkable absence of theorists in the study group preparing the ISR physics programme. As an example, I heard for the first time that quarks could result in observable effects at the ISR from a report by J. D. Bjorken at a Fermilab workshop in the autumn of 1971, two years after the discovery of deep inelastic scattering at SLAC. Fortunately contacts between experimentalists and theorists at CERN grew much closer, as demonstrated by the many workshops in preparation for LEP physics in which measurement criteria were clearly defined and physics priorities established.

The second subject (chapter 9, by P. Gregers Hansen), describes nuclear physics at the 600 MeV synchrocyclotron (SC), its main activity when particle physicists moved to higher energies. As I know little about this field I learned a lot from this chapter. I also read with great interest about the difficulties with the SC intensity upgrade in the early 70s in connection with the replacement of the old frequency modulator (a tuning fork) with a

rotating condenser built by industry, which almost led to a premature closure of the SC. The crisis was resolved only when CERN took full responsibility for the construction of the rotating condenser.

The last chapter of this section (chapter 10, by K. Winter) describes the CERN experiments on weak interactions from the middle of the 60s to the W and Z discovery. It is written in the style of a physics report and contains many technical details and formulae which, in my opinion, makes it difficult to read for non-physicists. Aspects of scientific policy, of interest for a history book, receive little attention (for example, it would have been interesting to read about the hesitation of CERN management in allowing the Gargamelle collaboration to announce the discovery of neutral currents). Nevertheless, it is very complete and clearly demonstrates the enormous impact that CERN results have had in this important field.

The third part of this book contains two chapters on engineering and technology at CERN. Chapter 11, by M. Crowley-Milling, describes the evolution of accelerator knowledge and expertise between 1960 and 1980. It demonstrates not only the high level of professional competence of CERN staff but also the innovations and risks which accompanied some of these projects. For example, it was at CERN that the first strong focusing proton synchrotron was built despite the uncertainties of this new concept (it would have been much easier and less risky to build a scaled-up copy of the Brookhaven Cosmotron or the Berkeley Bevatron). It was also at CERN that the first proton-proton collider was built, and stochastic cooling was invented and success-

# GEC ALSTHOM

**A commitment to excellence in applied superconductivity**

**Wires**

- NbTi / Cu
- NbTi / CuNi / Cu
- NbTi / CuNi
- Nb<sub>3</sub>Sn

**For**

- . MRI - MRS magnets
- . Collider magnets
- . Detector magnets
- . SMES applications
- . Fusion applications

**Cables**

**Aluminium jacketed conductors**

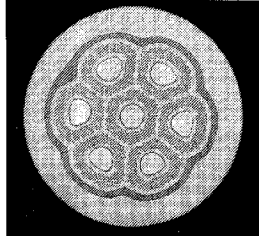

**AC Applications**

- . Current limiters
- . Transformers
- . Generators

**Gec Alsthom one of the world leaders in superconducting cables and wires**

For any further information, please contact us



3, avenue des Trois Chênes - 90018 Belfort Cedex, France  
Tel. +33 (0)3 84 55 32 26 - Fax +33 (0)3 84 55 16 15

# Powered Crates

Further to all our **CERN approved CERN-Spec. Crates** NIM-, CAMAC-, FAST BUS-, VXI- and VMEbus **Wes-Crates** supplies other Crates based upon these Systems.

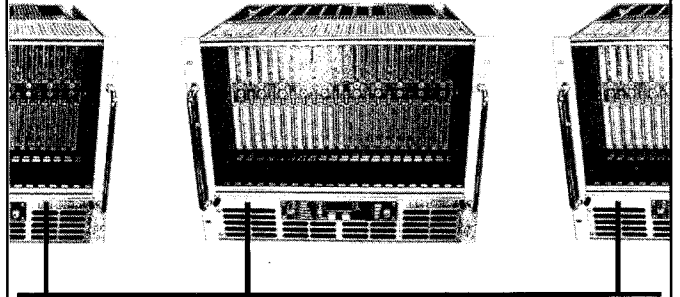

CAN remote control

ISO Layer 7: CANtrol® user defined CAL

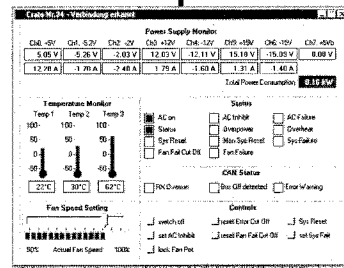

## METROLAB Instruments SA

**NMR PT 2025 MAGNETOMETER**  
very high accuracy and stability

For mapping of accelerator or imaging magnets

- Nuclear Magnetic Resonance of protons or deuterons
- Ranges : 0.04 to 13.7 Tesla
- Reproducibility : 0.1 ppm
- Multiplexer : up to 8x8 channels
- Field regulation by means of the plug-in RG 2040



**EPR VERSION**

1 ppm reproducibility below 32 Gauss

For measurements of superconductive magnets at ambient  
For calibration of magnets

- Electron Paramagnetic Resonance probes connectable to the standard Metrolab NMR PT 2025 magnetometer unit
- Ranges : 0.55 to 3.2 mTesla
- Accepts low homogeneity field

**METROLAB : 110, ch. du Pont du Centenaire CH-1228 Geneva Switzerland**  
tel : + 41 (22) 884 33 11 fax : + 41 (22) 884 33 10 E-mail contact@metrolab.ch

**USA : GMW tel : + 1 (415) 802 82 92 fax : + 1 (415) 802 82 98**  
**Japan : DMD tel : + 81 (3) 32 550 931 fax : + 81 (3) 32 559 869**

- 160 pin J1/J2
- opt. 95 pin J0 (2 mm)
- +3.3V/48V
- more user def. I/O-pins
- slot geographical address
- EMC
- ESD
- injection / extraction handle
- slot keying
- rear I/O transition boards
- fast 2 edge protocol
- ... and more features

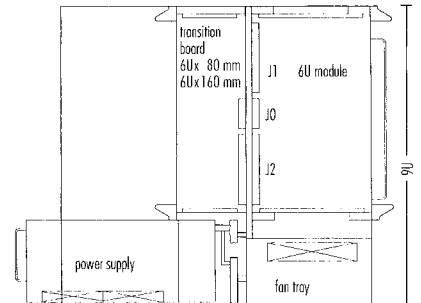

VME 64 Extension Compliance

Every **CERN-Spec.** so far has given rise to a **CERN-approved Crate** from:

**Crates and Power Supplies from WES-Crates** are flexible because of modular systems.

# WES-Crates

**Wes-Crates GmbH**  
Pattburger Bogen 33  
D-24955 Harrislee/Flensburg  
Germany  
Telefon 0461 - 77 41 77  
Telefax 0461 - 77 41 41  
International +49 461  
E-mail: sales@wes-crates.de



Zertifiziert nach  
ISO 9001  
Germanischer Lloyd  
Certification

Your contact in Geneva: HiTech Systems Sa, Avenue Wendi 16, 1203 Geneva, Tel.: 022 / 344 77 88, Fax: 022 / 45 65 51

Your contact at PSI and ETH Zürich: Dipl.-Ing. Kramert AG, Villigerstr. 370, CH-5236 Remigen, Tel.: 056 / 284 15 55, Fax: 284 50 55

fully applied to the first proton-antiproton collider. One can also find many other less known technical innovations, some of which quickly found applications in industry.

The last chapter, by I. Gambaro, describes the development of electronic tracking detectors at CERN from 1964 to the late 70s. This period was marked by the invention of the Multiwire Proportional Chamber by G. Charpak, which revolutionized experimental particle physics and was the origin of other tracking detectors such as the drift and time projection chambers. A detailed description of many tracking detectors used in CERN experiments gives the inexperienced reader a precise idea of how such detectors were used in practice.

This book describes in more than 600 pages the very interesting history of CERN during a period in which the laboratory became the world's leading centre of particle physics. Written by a variety of authors,

science historians or scientists, the style is not uniform. Scientists tend to emphasize scientific and technical aspects, while historians focus more on managerial, political, financial and social aspects, which scientists generally ignore. At the same time, science historians may miss some important technical detail which was the key to a success or failure of a project. Perhaps books like this should be written by a historian and a scientist together.

It clearly gives the impression that recent advances in particle physics owe much to CERN. As well as documenting CERN's achievements, this book displays clearly the importance of the groundwork which makes such achievements possible. Without adequate preparation, inspired foresight and staunch support at all levels, even the best research ideas fall on infertile soil.

*by Luigi Di Lella*



*Distinguished CERN physicist Luigi Di Lella is also Chairman of CERN's Archive Committee.*

## Superconducting success

**W**ith CERN's LEP electron-positron collider operating at 92 GeV per beam (184 GeV collision energy) and with 240 superconducting radiofrequency accelerating cavities installed, the finishing line is in sight for a long push which began in 1979.

In 1979, when LEP was still on the drawing board (the project was formally approved by CERN Council in December 1981), CERN's Executive Director General John Adams, with his legendary foresight,

launched a modest research and development programme for superconducting radiofrequency accelerating cavities with the aim of boosting LEP performance.

Meanwhile development was already underway at a number of other laboratories, notably Cornell (for its own CESR electron-positron collider), Karlsruhe (for DESY) and KEK (Japan, for the TRISTAN electron-positron collider). But with CERN's decision to enter the electron stakes with LEP, a whole

range of new skills would have to be mastered.

LEP's initial goal, equipped with conventional (copper) cavities operating at room temperature, was to mass produce the Z particle, the carrier of the neutral current of the weak interactions, around 91 GeV. But once this physics would be thoroughly explored, the objective was to go higher and at least enable LEP to produce pairs of W particles, the electrically charged partner of the Z. (In LEP's electron-positron

*From Z to WW. The steady growth of superconducting accelerating power in CERN's LEP electron-positron collider.*

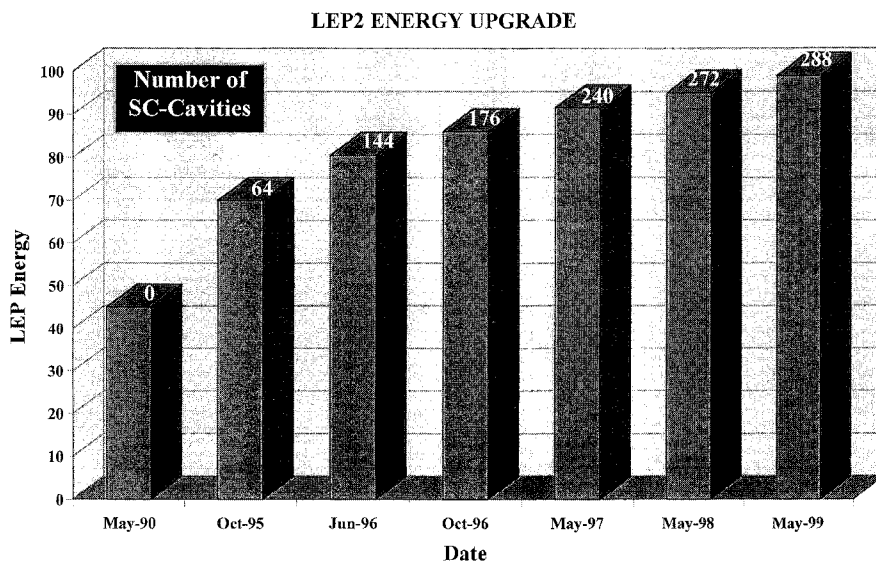

collisions, neutral Zs can be produced singly, but Ws can only be produced in oppositely charged pairs.)

To produce such energies needs about another 2000 Megavolts, and to drive this economically demanded the low power consumption of a superconducting approach, with energy losses some hundred thousand times less than those of conventional units, and promising more powerful accelerating field gradients.

At CERN, already well endowed with workshop expertise, work began in association with several European universities - Geneva, Genoa, Paris and Wuppertal. (The latter had been developing superconducting technology with Darmstadt, subsequently to commission its own superconducting Dalinac.)

At that time, it had been realized that a spherical cavity drawn from solid niobium or spun from sheet (rather than a welded pillbox construction) provided an optimal approach, minimizing troublesome

'multipacting' due to electron resonances inside the cavity.

In parallel, sensitive methods were developed to map the temperature of the cavity surface and look for hot spots where losses would be likely to occur.

This was the start of a heroic quest to attain the severely demanding conditions needed to guarantee that the superconducting cavities, together with their ancillary power couplers, tuners, etc, would deliver their promised performance. In 1983, a 5-cell niobium structure for CERN was tested in an electron beam at DESY's PETRA ring.

By operating at the 352 MHz already envisaged for LEP's initial complement of ambient temperature copper cavities, existing r.f. generation and distribution infrastructure could be taken over.

In parallel, CERN was also looking at a promising new approach, using copper sputter-coated with niobium, rather than expensive niobium sheet. As superconductivity is essentially a surface phenomenon, with the

Meissner effect limiting the penetration to only 0.05 microns, the idea was to provide the superconducting layer as an almost perfect thin sheet. Over the next few years, this R&D progressed in parallel with work towards solid niobium cavities.

In 1987, the first LEP-type cavity, made of solid niobium, was operated for more than 10,000 hours in CERN's SPS synchrotron. Four more such cavities were built, two at CERN and two in industry, and were eventually mounted near Point 2 of the 27-kilometre LEP ring in 1990 (LEP had begun operation in 1989).

However by this time, the advantages of niobium-coated copper were becoming clear. Thermal stabilization is enhanced by the good conductivity of the underlying copper and losses are halved, while the material cost is substantially reduced. In a crash programme, the pilot niobium cavity was replaced by a module of 2 niobium-copper units.

Although CERN was committed to the initially ordered solid niobium units, the decision was taken to switch to niobium-coated copper for the bulk installation programme.

Cryostat design and assembly was perfected, power and high-order mode couplers developed, and the impressive arsenal of associated technology assembled, with electron welding, fully automated chemical surface treatments, and high pressure rinsing using pure, dust-free water. All this know-how had to be passed to industry to enable the hundreds of units to be produced in European factories. In 1990, contracts were signed for 168 such cavities, using three main suppliers.

After trials with initial prototypes, installation of niobium-coated cavities

*In 1999, LEP, equipped with its final complement of 288 cavities, is scheduled to operate with a collision energy close to 200 GeV.*

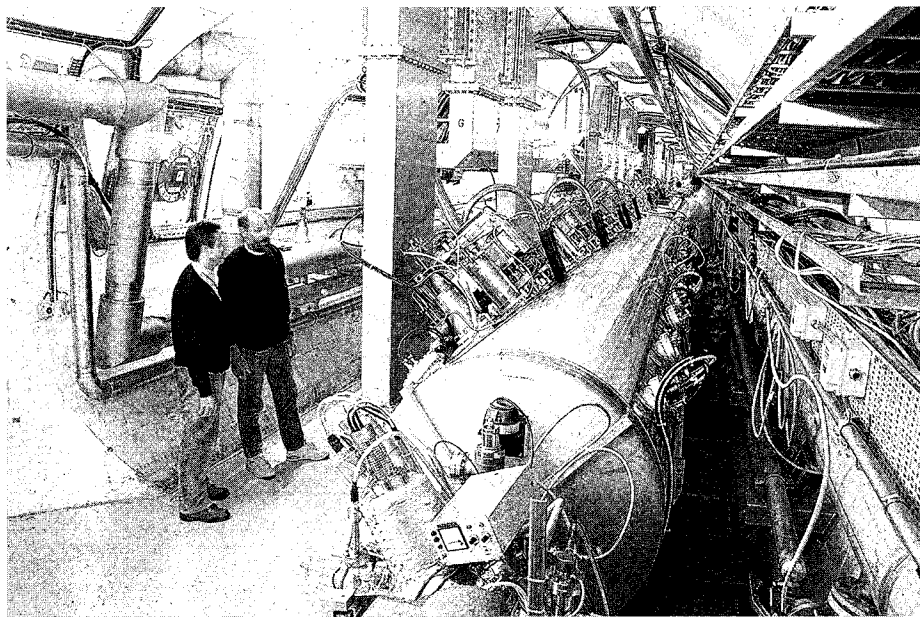

scheduled to operate with a collision energy close to 200 GeV, a fitting conclusion to the foresighted decision to include a superconducting option and twenty years of effort.

As well as driving LEP, the versatile new technology could also find its way into new applications.

*The Editor would like to thank Enrico Chiaveri for his help in compiling this article.*

began in earnest in 1993, running alongside the 16 solid niobium cavities installed the previous year. With the cavities themselves performing well, attention turned towards perfecting ancillary equipment such as power couplers. Here too technical solutions had to be developed and the necessary quality control ensured.

After intensive tests, on 31 October 1995 the impressive additional accelerating power, now installed in each quadrant of the ring, was marshalled. LEP, which had been operating around the Z resonance near 91 GeV, for the first time ran at a substantially higher collision energy, 130 GeV, giving physicists their first look at new territory.

After more superconducting cavities were brought in during the 1995-6 winter shutdown, LEP officially became LEP2, attaining the 161 GeV collision energy level needed to produce W pairs.

The development, supply, installation and operation of some two hundred cavities, together with

the impressive radiofrequency power and control system, is the obvious focus of all this work. However substantial effort has also gone into cryogenics, civil engineering, electricity distribution and cooling equipment.

In 1999, LEP, equipped with its final complement of 288 cavities, is

*Production and handling of LEP's superconducting cavities demands very clean conditions all along the line.*

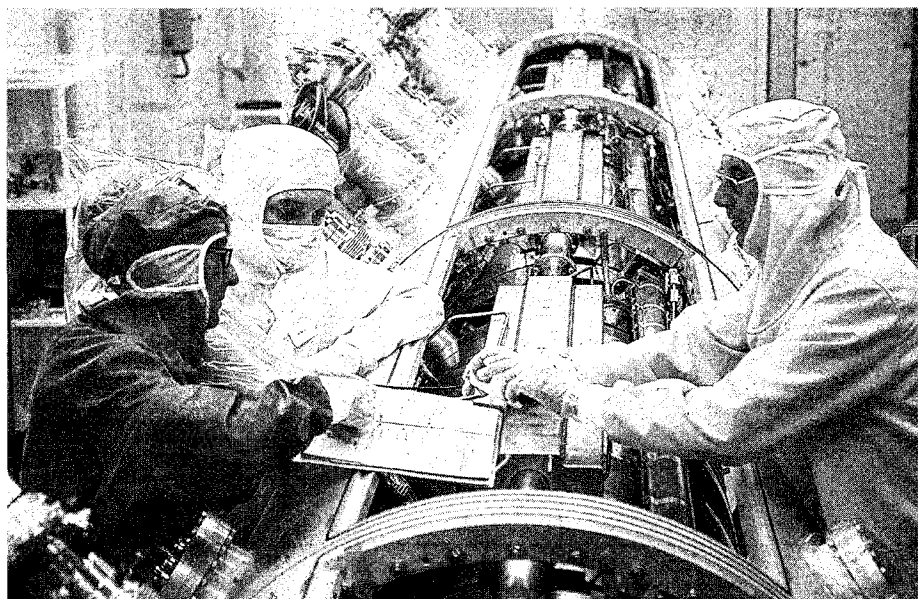

**High voltage**  
**. High precision**  
**.. High quality**  
**... Low price**

**HV-sources in**

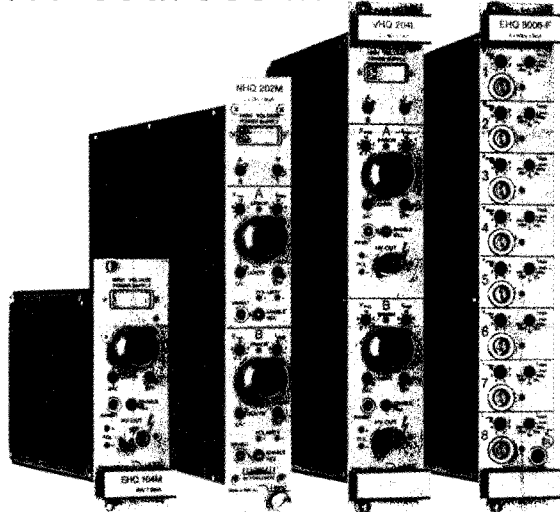

**NIM, CAMAC, VME & CAN**

- including instruments with 100 pA / 10 mV resolution
- Ripple  $< 2 \text{ mV}_{p-p}$ , Stability  $< 5 \times 10^{-5}$
- cost effective Multi-channel systems of any configurable size

**HV-sources for  
Special Applications**

- PMT base integrated HV-supplies, e.g. PHQ 2020 for Philips XP2020

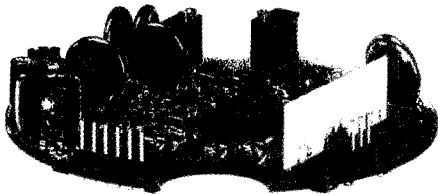

- Detector mounted HV-supplies

**iseg**  
Ingenieurbüro Spezialelektronik Gleisberg

**STRUCK**

Dr. Bernd Struck, Baeckerberg 6, D-22889 Tangstedt  
Phone: + + 49 (0) 4109 55-0, Fax: + + 49 (0) 4109 55-133  
E-mail: sales@struck.de, http://www.struck.de

**Associate Director —  
Accelerator Development  
University of Wisconsin-Madison  
Synchrotron Radiation Center (SRC)**

The University of Wisconsin-Madison seeks an innovative and creative Accelerator Scientist to lead the accelerator activities at the Synchrotron Radiation Center (SRC). This position carries responsibility for directing all activities relating to the ongoing development operation and maintenance of the "Aladdin" Storage Ring at the SRC. The Associate Director will report to the Executive Director of the Synchrotron Radiation Center and will be expected to coordinate and supervise the activities of four functional organizational groups (Accelerator Technology, Engineering, Controls, and Operations) through their respective Group Leaders. These groups are responsible for developing new initiatives in synchrotron technology for Aladdin, managing the 24-hour operation of the facility, maintaining and upgrading the injector, storage ring, support equipment, control systems, insertion devices, and other facilities.

The Associate Director will be expected to: conduct accelerator research to improve the characteristics of the synchrotron radiation utilized by several state-of-the-art beamlines and experimental systems installed on the storage ring; consult and collaborate with other synchrotron facilities regarding improvements to the stability, lifetime, and brightness of the synchrotron source; participate in the development of new initiatives and grant proposals for the funding of the facility by the National Science Foundation and other federal and industrial institutions; and work with the Associate Director of Research to provide state-of-the-art research facilities that will satisfy the needs of scientists performing their research at the Center and to actively participate in the innovations that create new research opportunities for Users.

Presently, the SRC operates the Aladdin storage ring at energies of 800 MeV and 1.0 GeV in support of User research interests. Of the four long straight sections, three contain insertion devices to enhance the spectrum for particular research applications. The Associate Director will play a leading role in Aladdin development programs including: participating in the planning for an insertion device in the fourth straight section, initiating and supervising studies to increase the beam current, increasing the stability of the beam in position and size, and to improve the lifetime of the beam while maintaining or reducing the beam emittance.

To be considered for this position, send curriculum vitae and reference list to **Mr. Clay Vinje, UW-Madison, Synchrotron Radiation Center, 3731 Schneider Drive, Stoughton, WI 53589**, by 2/27/98. Unless confidentiality is requested in writing, information regarding applicants must be released upon request. Finalists cannot be guaranteed confidentiality.

# Around the Laboratories

*Celebrating the first beam stored in the electron ring of DAFNE, the phi-factory project of the INFN National Laboratory in Frascati.*

## FRASCATI DAFNE complete

**O**n October 25 the first beam was stored in the electron ring of DAFNE, the phi-factory project of the INFN National Laboratory in Frascati.

This marked the conclusion of DAFNE construction, approved by the INFN Board of Directors in June 1990 and which began in April 1993 when the historic ADONE collider was shut down and dismantled. Final commissioning aims to bring DAFNE into operation at the beginning of 1998.

DAFNE is a double ring electron-positron collider with a design luminosity of  $5 \times 10^{32} \text{ cm}^{-2} \text{ s}^{-1}$  at the phi resonance (1.02 GeV). Its main physics motivation is precision measurement of CP-violation in neutral K decays. For the accelerator, to achieve this design luminosity is a challenge, as the maximum figure so far obtained in this low energy range is almost two orders of magnitude smaller.

The high current approach is similar to other 'particle factories' - the beauty factories under construction at SLAC, Stanford (PEP II) and KEK, Japan (KEKB). DAFNE's electron and positron beams are stored in two 100 m long separated rings in the same horizontal plane with horizontal crossing in two low-beta interaction regions at an angle of 25 mrad.

The lattice of each ring consists of 4 achromats, each housing a 2 m 1.8 T normal conducting wiggler. This novel configuration substantially improves the radiation damping rate while offering the advantage of wide emittance tunability. This allows a large number of bunches to be stored in each beam, without pushing the



beam-beam tune shift to extremely high values, while the luminosity can be quite large, being proportional to the number of stored bunches. However the high stored current sets stringent requirements on all accelerator subsystems.

The new injector complex, operational with both electrons and positrons, has been sized to store, in each ring, up to 120 bunches of  $10^{11}$  particles in about 10 minutes, thus maintaining the average luminosity at some 70% of its peak value.

Particular care has been taken with the vacuum system, capable of maintaining an average pressure of  $10^{-9}$  Torr under a radiation load of 50 kW from wigglers and bending magnets. Using a special 10 m long, single-piece aluminium vacuum vessel, radiation leaves a central beam region to reach an "antechamber" through a narrow slot, where it hits several water-cooled copper absorbers. The pumping system is a combination of titanium sublimators and sputter ion pumps.

The longitudinal multibunch

instabilities called for a special design of the 368 MHz 250 kV radiofrequency cavities, equipped with waveguide absorbers which strongly damp higher order modes (HOM) excited by the beam.

All vacuum chamber components have low parasitic loss coefficients. Residual instability can be damped using a longitudinal feedback acting on each single bunch, realized in collaboration with SLAC and Berkeley. This system has been successfully tested on the ALS light source at Berkeley and PEP II at SLAC.

The main experiment to run on DAFNE is KLOE (July, page 8), concentrating mainly on CP-violation measurements. The DAFNE interaction region for KLOE presented many challenges. The vacuum chamber is a beryllium sphere 10 cm in diameter and 500 micron thick with an inner sleeve of 50 micron thickness to provide RF continuity.

The low-beta insertion squeezing the beams inside the detector covers



*Fish-eye view of the DAFNE hall after installation of the main rings.*

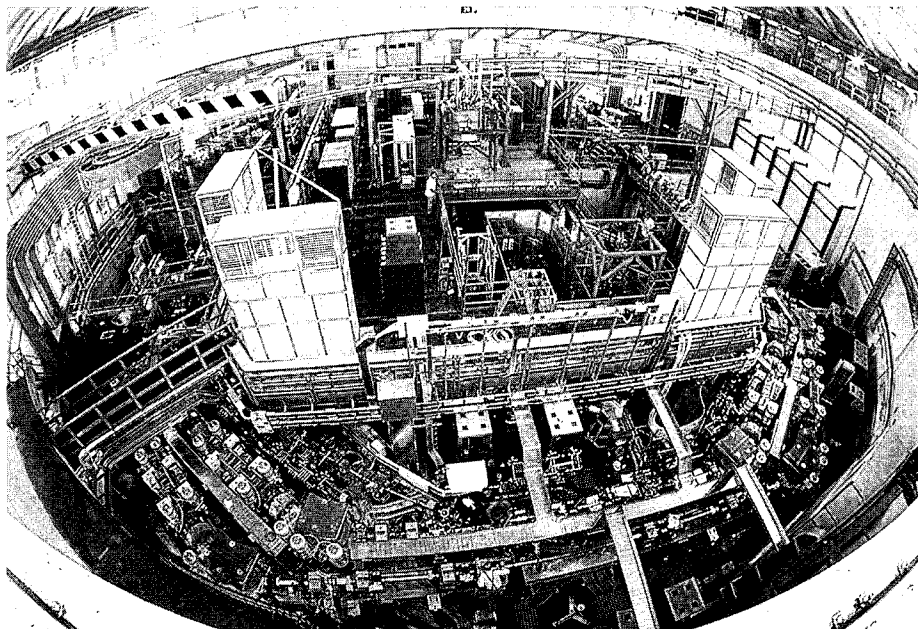

some 1% of the solid angle and operates in the detector field. Its large magnetic perturbation on DAFNE is corrected using the rotating frame method suggested by M. Bassetti for DAFNE. The insertion consists of 6 permanent magnet quadrupoles, with adjustable rotation and position. A pair of external superconducting solenoids cancels the betatron coupling due to the detector field.

Another experiment will be installed in DAFNE's second interaction region. Run by the FINUDA collaboration, it will study the physics of hypernuclei, when an ordinary nucleon in a nucleus is replaced by a strange baryon such as a lambda or sigma.

Such artificial hypernuclei allow nuclear properties to be studied in the presence of strange quarks. The cylindrical FINUDA apparatus consists of an interaction/target region, a tracker and an outer scintillation array, surrounded by a superconducting solenoid.

The third experiment, much smaller, is DEAR, to study kaonic atoms. This compact detector does not require a magnetic field and will be performed at the first stage of DAFNE operation.

A description of DAFNE and its status can be found at <http://www.lnf.infn.it/acceleratori/dafne.html>

## NOVOSIBIRSK VEPP-2M phi-nesse

**A**t the summer conferences two experimental groups from the Budker Institute, Novosibirsk, announced new results from the VEPP-2M electron-positron collider. The CMD-2 detector (November 1994, page 9) completed a scan of the collision energy range from 360 to 1400 MeV aimed at high precision measurement of electron-positron annihilation into hadrons.

Preliminary results on the pion form factor show a nice excitation curve of

*The CMD-2 detector at the VEPP-2M electron-positron collider at the Budker Institute, Novosibirsk, sees the first phi decay to eta prime and a gamma ray. CMD-2 observes six events in the expected signal region in a scatter plot of the invariant mass of two hard photons vs the energy of the softest photon, where the expected background is less than one event. The three events outside this region are compatible with background.*

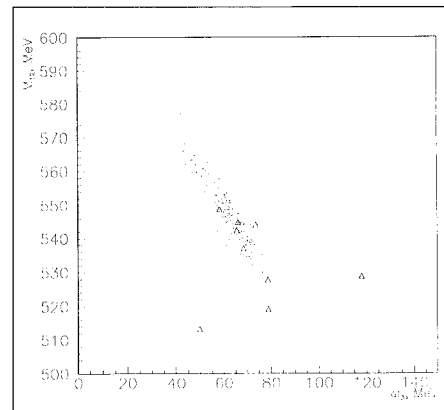

the rho meson with clear rho-omega interference. Work is in progress to better understand systematic uncertainties which are currently estimated at 1.5% and are important to improve the precision of the calculations of the hadronic contributions to the anomalous magnetic moment of the muon and the running electromagnetic coupling constant.

With 5.5 million phi mesons CMD-2 can look for its rare decays. Analysis confirms the existence of conversions to electron-positron with an eta meson (discovered at VEPP-2M in 1985) and with a neutral pion (first observation) at the expected levels of  $10^{-4}$  and  $10^{-5}$  respectively.

However, the main feature is the first observation of phi decay to eta prime and a gamma ray - the only magnetic dipole decay previously not seen and vital for the consistent understanding of the quark model predictions.

CMD-2 observes six events with an expected background of less than one (a scatter plot of the invariant mass of two hard photons vs the energy of the softest photon shows events as expected from simulation). This corresponds to branching ratio of  $1.2 + 0.7 - 0.5 \times 10^{-4}$ , ruling out a high admixture of glue in eta prime.

*The VES large aperture magnetic spectrometer at the Institute for High Energy Physics (IHEP), Protvino, near Moscow, where the SERP-164 experiment has finished data taking for its study of meson resonances in the mass range 1.5-2 GeV.*

The SND detector (April/May 1995, page 17) collected even a bigger sample of 6.5 million phi mesons. About half the available statistics has been analysed. The group also observes one example of phi decay to eta prime, corresponding to an upper limit of less than  $1.7 \times 10^{-4}$ . For the first time the electric dipole decays to two neutral pions and a gamma and neutral pion, eta and gamma are measured with relative probabilities at the  $10^{-4}$  level.

It is amusing that due to the large number of phi mesons created, it became possible to tag eta mesons produced with a 1.3% probability in the radiative decay (a 362 MeV photon serves as a good tag) and look for their rare decays.

In this way electron-positron colliders become competitive with usual sources of eta mesons at hadronic machines. Looking for parity and CP-violating decays of the eta to two pions, SND placed for the first time a limit on its decay into two neutral pions, while CMD-2 improved the upper limit for the decay into two charged pions.

Although these limits are still far from the minute Standard Model predictions, they unambiguously show the high potential of future phi factories for eta meson studies.

Most of the reported results are still preliminary and analysis is still underway. In October VEPP-2M started another running season which will probably be the last before DAFNE starts operation in Frascati (see previous story). Both VEPP-2M detectors plan to double their data samples at the phi meson as well as repeat measurements in the rho- and omega-meson energy range.

Next summer, work will start on implementing the round beams to improve VEPP-2M luminosity at the

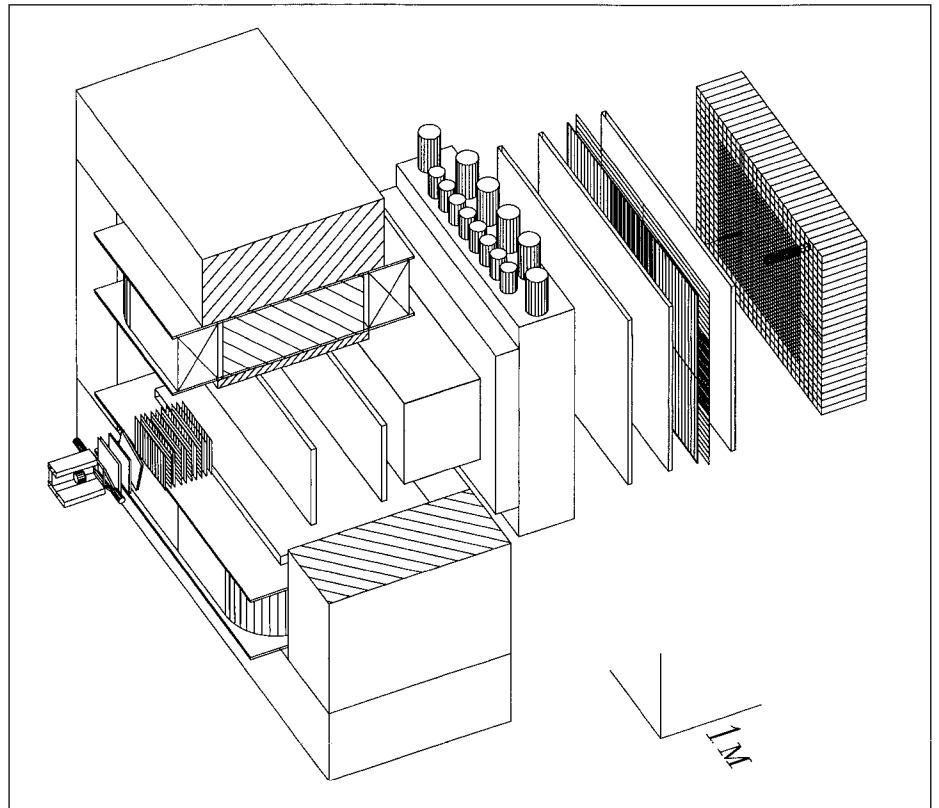

phi-meson by a factor of 20 and open the way to a Siberian phi-factory.

either by quantum numbers which are impossible for conventional mesons, for example  $1^{+-}$ , or by anomalous relative decay rates into different channels.

## PROTVINO Hybrid mesons

This year at the Institute for High Energy Physics (IHEP), Protvino, near Moscow, the SERP-164 experiment on the VES large aperture magnetic spectrometer finished data taking.

Its main goal is a systematic study of meson resonances in the mass range 1.5-2 GeV, where one could expect exotic states, glueballs and hybrids. Hybrid mesons (a quark-antiquark pair together with a valence gluon) can manifest themselves

SERP-164 has some  $10^9$  events of pion-nuclear interactions at 37 GeV and used partial wave analysis to study the production of mesonic states with different quantum numbers. In particular, the presence of a  $1^{+-}$  exotic wave was found in the production of eta-pion, eta'-pion, rho-pion,  $f_1(1285)$ -pion and  $b_1(1235)$ -pion systems.

The most significant result was finding hybrid properties. Above 1.5 GeV, production of eta'-pion with  $1^{+-}$  is much higher than that of eta-pion, while in reactions with nonstrange light quarks, eta' is normally produced half as frequently as eta. This can be explained by the fact that

*Cross-sections of the vacuum vessel of the Munich Tritron superconducting separated orbit cyclotron (M: magnet sector, R: radiofrequency-cavity). The high accelerating voltage per turn results in a turn separation of several cm instead of mm, opening the possibility of a high power/low loss cyclotron.*

eta', with a strong gluon coupling, has an affinity with hybrid states.

No narrow  $1^{++}$  resonant states were observed. However, in the eta-pion system at masses around 1.4 GeV some peculiarities were found in the behaviour of the amplitude and phase of the exotic wave, as observed also at the Japanese KEK Laboratory and confirmed recently at Brookhaven.

It is still an open question whether it is a manifestation of a very broad resonance of width 400 MeV, or of some other dynamics (for example threshold effects produced by the opening of another channel such as  $f_1(1285)$ -pion). More studies are foreseen.

The mesons with conventional quantum numbers can also have hybrid properties. For example in detailed studies of the  $\pi(1800)$  meson, which has pion quantum numbers, anomalous decay rates were found, with high probability for decay into  $f_0(980)$ -pion,  $f_0(1200)$ -pion and low probability for decay into rho-pion. Such properties have been predicted for hybrid mesons in model calculations. This is good reason to suppose that  $\pi(1800)$  has a significant hybrid content.

This observation can also shed light on some properties of charmed particles. Due to the closeness of the masses of charmed D-mesons and the  $\pi(1800)$ , this resonance affects the relative probabilities of D decays. If  $\pi(1800)$  has a significant hybrid content, this can increase the probabilities of CP-violating decays of D-mesons and oscillations between D and its antiparticle.

With the VES setup being upgraded, future VES plans also include more data taking next year in a new research programme covering studies of: resonance production in the Coulomb field of nuclei; energy-

and nuclear-dependence of resonance production; and diffractive production of charmed particles.

## MUNICH First beam in superconducting separated orbit cyclotron

The first accelerated beam in a superconducting separated orbit cyclotron at Munich bodes well for this pioneer approach.

While conventional cyclotrons can provide ion beams with high average intensity, say some mA, in recent years an increasing demand for proton beams with average currents of more than 10 mA for the production of high neutron fluxes, e.g. for accelerator driven nuclear power plants, and/or for transmutation of nuclear waste, begs an alternative approach.

The key to such a high power/low loss cyclotron is a high accelerating voltage per turn, resulting in a turn separation of several cm instead of mm. This facilitates extraction and opens the possibility of independent magnetic channels with alternating gradients.

The high accelerating voltages can be obtained with superconducting radiofrequency cavities. Due to the high current density in the superconducting coils, the coil width (3 mm) is negligible compared to that of the steel frame of each magnetic channel and the beamwindow. The total radial width of the magnetic channel is equal to the turn

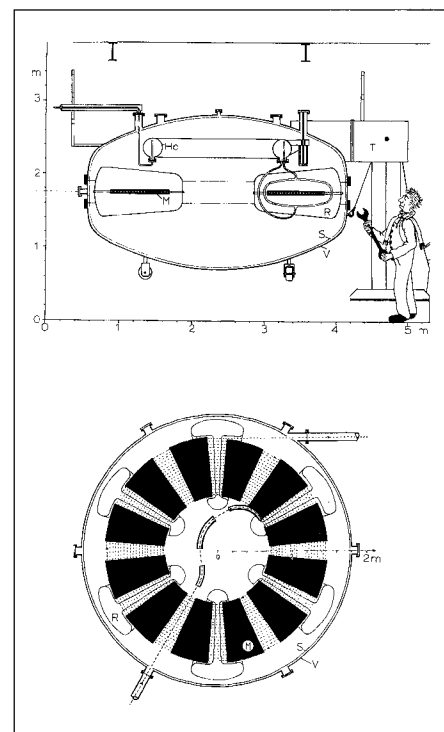

separation. This principle - the Separated Orbit cyclotron - was proposed in 1963 with non-superconducting elements. However superconductivity is the key to its application.

A small prototype, the Tritron, was designed at the Accelerator Laboratory of both universities of Munich. The injection radius is 66 cm, the extraction radius 145 cm, and the energy gain factor about 5. Six sector-shaped cavities (170 MHz) with 20 beam holes in parallel provide for an accelerating voltage of 3 MV on the final turn.

To keep the voltage low, the turn separation was made as small as possible (40 mm), resulting in a magnetic channel aperture of only 10 mm. Almost 240 channel magnets with alternating gradients are arranged in 12 flat sectors, guiding the beam along almost 20 turns. Arrays of 20 small superconducting

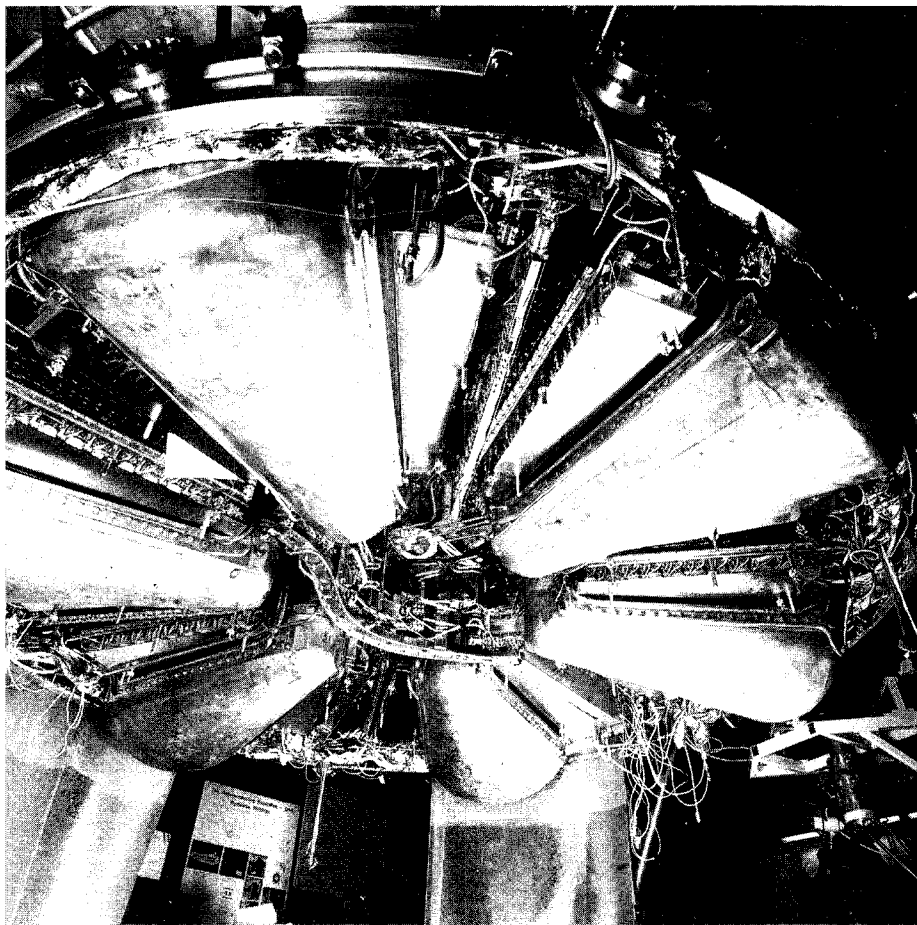

Upwards view into the Munich Tritron cyclotron cryostat, showing its array of radiofrequency cavities and magnet sectors.

axial steering magnets are positioned in three of the intermediate sectors. The cavities are made of copper electroplated with lead-tin, and the machine is cooled to 4.5 K.

On September 12 all phases and amplitudes were adjusted to accelerate a sulphur beam from an energy of 40.3 MeV around 6 turns, reaching 72 MeV. This shows that the principle of a separated orbit cyclotron works. Beam dynamics will now be studied in more detail, and the transmission will be improved by proper field settings.

Based on these results, future separated orbit cyclotrons could use enlarged turn separation, say 10 cm, with a beam aperture of about 5 cm. This would enable acceleration of high intensity beams with low losses.

## NIKHEF Two proton knock-out

The nucleus may contain up to a few hundred strongly interacting nucleons. The interaction of so many particles is immensely complex and nuclear properties are therefore commonly described by theories, like the nuclear shell model, in which the sum of all interactions is approximated by a mean field.

However, single proton knock-out experiments have indicated that

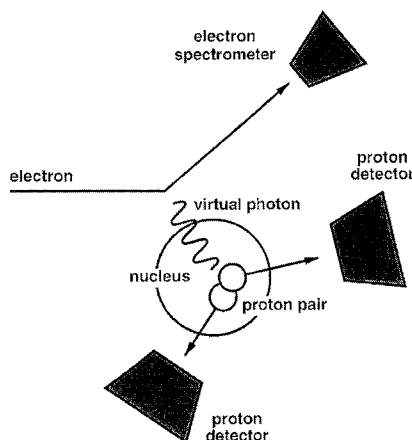

Knock-out of a correlated proton pair in electron scattering.

protons spend only a part of their time in such a field. For neighbouring nucleons the mutual interaction, highly repulsive at small internucleon distances, seem to dominate and give rise to strong short range correlations.

Experiments at NIKHEF, in which proton pairs are ejected from oxygen nuclei, may shed more light on such correlations. The high-precision experiments in Amsterdam, in which triple coincidences between a scattered electron and two ejected protons are measured, give - for the first time - detailed information on the motion of proton pairs inside the nucleus.

In the experiments an oxygen target is struck by electrons extracted from AmPS, the Amsterdam Pulse Stretcher. The almost continuous beam current provided by AmPS is crucial since the cross-sections for the reactions are extremely small, typically  $10^{-11} \text{ fm}^2/(\text{MeV}^2 \text{ sr}^3)$ , whereas the background from accidental coincidences is relatively large.

The oxygen target, a so-called 'waterfall' target developed by the INFN group in Rome, consists of a waterfilm in a cell filled with hydrogen gas. The film is created by pumping water through a thin slit; its thickness can be varied by changing the pumping speed.

Two newly built and highly segmented plastic scintillator arrays detect the ejected protons. Both detectors, covering solid angles of 225 and 550 msr, and the accompanying electronic VME-based read-out system, were developed in collaboration with the Free University Amsterdam. The scattered electrons are picked up by a magnetic spectrometer.

In a series of measurements with a luminosity around  $2 \times 10^{36}$  nucleons/



# UNIVERSITY OF OXFORD

## Department of Physics Senior Mechanical Design Engineer (RS2)

£21,016 - £27,985 p.a.

The position of Senior Mechanical Design Engineer in the Department of Physics will become available within the next two years. Early recruitment of a replacement is considered essential for this key position which is jointly funded by the Particle Physics and Astronomy Research Council and the Department and which is available immediately.

The postholder will be required to lead a small office producing designs of experimental apparatus and to process these designs through to unique research hardware for use within the Department or in large multinational collaborative projects. The position requires a 'self starter' with 'hands on' experience of CAD and CAE systems which are well supported and updated regularly. The current softwares are Autocad based with 'Algor' FEA running on a Windows NT system. Short periods of work overseas will be necessary.

**Applicants should be Chartered Engineers or equivalent and preferably hold a Master's degree in an engineering discipline together with at least ten years post qualification experience. Letters of application together with a CV and the names and addresses of two referees should be sent to the Administrator, Department of Physics, Clarendon Laboratory, Parks Road, Oxford OX1 3PU by 31 January 1998 from whom further particulars can be obtained (e-mail e.davies1@physics.oxford.ac.uk; telephone no. 01865 272201).**

The University is an Equal Opportunities Employer.



La Faculté des sciences de l'Université de Lausanne met au concours un poste de

**professeur ordinaire de physique théorique**  
spécialisé dans le domaine des particules élémentaires  
et des interactions fondamentales.

Entrée en fonction : 1<sup>er</sup> septembre 1998 ou date à convenir.

Le titulaire devra participer à l'enseignement de la physique théorique, en collaboration avec ses collègues théoriciens de l'Université et de l'Ecole Polytechnique Fédérale de Lausanne. Le nouveau professeur poursuivra des recherches et dirigera des thèses de doctorat.

Les candidatures (c.v., liste des publications, tirés à part choisis - trois au plus, projet de recherches, trois références) doivent parvenir avant le **31 janvier 1998** au Doyen de la Faculté des sciences, Collège propédeutique, CH-1015 Lausanne (Suisse).

Renseignements complémentaires: Prof. J.J. Loeffel, Institut de physique théorique, Tél. ++41 21 692 37 50/51; fax ++41 21 692 37 65; e-mail: jean-jacques.loeffel@ipt.unil.ch.

Soucieuse de promouvoir l'accès des femmes à la carrière académique, l'Université encourage les candidatures féminines.

# UNIVERSITY OF TORONTO

## Tenure Track Faculty Position Joint Appointment in the

## Department of Astronomy and Physics

The Departments of Astronomy and Physics will make a tenure track appointment to the rank of Assistant Professor with an expected starting date of July 1, 1998. This is one of a number of appointments being made in the Department of Astronomy, Department of Physics and the Canadian Institute for Theoretical Astrophysics.

We seek candidates with a Ph.D. in Astronomy and/or Physics, with proven or potential excellence in both research and teaching. Our goal is to find a candidate with either a theoretical or experimental background who will promote interactions between the departments. The appointment will be made in the area of astrophysics, broadly defined as the interface between astronomy and physics. This includes, but is not limited to, cosmology, nonlinear dynamics, and plasma, particle, nuclear and high energy astrophysics. We invite prospective candidates to visit our home pages at:

<http://www.{astro,physics,cita}.utoronto.ca/>

Salary will be commensurate with qualifications and experience.

Applications, including a curriculum vitae and three letters of reference, should be sent to:

**Professor Pekka K. Sinerva**  
Chair

**Department of Physics**  
**University of Toronto**  
**60 St. George Street**  
**Toronto, Ontario, Canada**  
**M5S 1A7**

or

**Professor E. R. Seaquist**  
Chair

**Department of Astronomy**  
**University of Toronto**  
**60 St. George Street**  
**Toronto, Ontario, Canada**  
**M5S 3H8**

The deadline for the receipt of applications and letters of recommendation is January 15, 1998.

In accordance with Canadian immigration requirements, priority will be given to Canadian citizens and permanent residents of Canada. The University of Toronto is committed to employment equity and encourages applications from all qualified individuals including women, members of visible minorities, aboriginal persons, and persons with disabilities.

*Experiments at NIKHEF, in which proton pairs are ejected from oxygen nuclei, help shed light on inter-particle correlations. This shows one of the highly segmented proton detectors.*

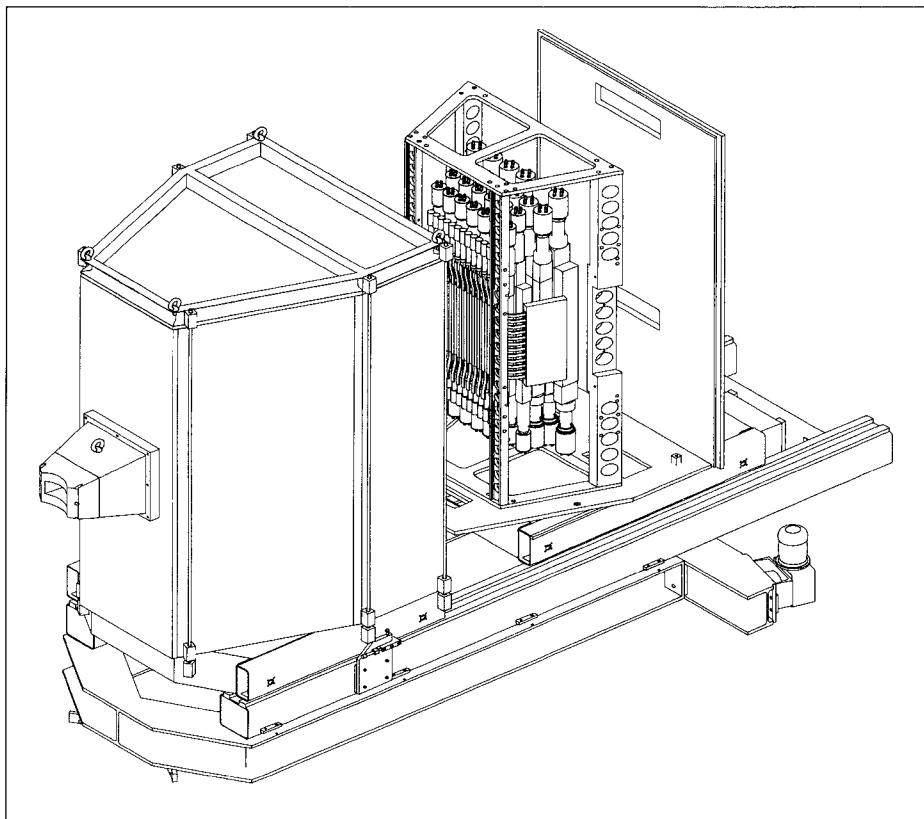

cm<sup>2</sup> s, about 5000 true triple coincidences were collected. The energy and momentum transfer were 210 MeV and 300 MeV/c, respectively, while the proton energies ranged from 40 to 160 MeV.

The measured momenta of the scattered electrons and the ejected protons yield information on the initial state of the proton pair.

First, the excitation energy and the momentum of the residual carbon 14 nucleus are determined from these momenta. Assuming a quasi-free reaction, the momentum of the recoiling nucleus does not change during the reaction and is equal and opposite to the centre-of-mass momentum of the initial proton pair.

The excitation energy spectrum reflects the binding energies of the protons inside the nucleus. In the nuclear shell model, oxygen 16 is

described as a doubly closed shell nucleus and the less bound nucleons move in the shell closest to the Fermi level. If such protons are ejected, the residual carbon 14 nucleus is left in the ground state or in a low excited state.

For each transition, angular momentum conservation dictates the relations between the relative angular momentum and the centre-of-mass angular momentum of the proton pair. The latter is related to the momentum of the recoiling carbon 14 nucleus. The measured recoil momentum distributions clearly show the correspondence between the excitation energy and the centre-of-mass angular momenta of the ejected pairs.

A combined analysis of the low energy part of the excitation spectrum and the momentum distri-

bution of the carbon 14 nucleus shows that most of the ejected protons have zero relative angular momentum (including opposed spins). This means that their average distance inside the nucleus was about 1 fermi, small enough to expect large effects of short-range nucleon correlations. The predominating direct knock-out of S-state proton pairs can be considered as a strong indication for the importance of such correlations. On the other hand, contributions of other processes to the cross-section, as supported by recent theoretical calculations, cannot be excluded. The reaction mechanism is studied in more detail in an additional experiment for which data analysis is in progress. Comparison of the complete data set with the results of microscopic calculations may give further evidence for short range correlations.

## CERN Computing School

The 20th CERN School of computing, in Pruhonice, Czech Republic, from 17 - 30 August was organized in collaboration with the Institute of Physics, Prague, and the Charles University, Prague, and was opened in the presence of J. Niederle, President of the Council of International Cooperation of the Czech Academy of Science, Czech Delegate and Vice-President of the CERN Council. Funding for certain students attending the School came from UNESCO and the European Commission.

The School was proud that for the first time all computing and peripheral

Ranges probed by solar neutrino experiments in comparison to constraints from many other sources, together with predictions of some theoretical models. Also shown is the potential of the GENIUS project using germanium detectors in liquid nitrogen, at various scales. The lines correspond to different assumptions for the neutrino mass hierarchy.

equipment was staged by CERN. The main computer setup consisted of 33 Windows NT Workstations, 16 on loan from Elonex, 16 from Hewlett Packard, and 1 from Digital Equipment Corporation. One dual processor CPU was lent by SUN Microsystems France. Equipment was delivered to CERN, set up in the CERN Computer Centre, all the necessary software installed and tested, dismantled, packed and then sent to Pruhonice, where network connections had been assured.

The School's themes were: Information Systems, Software Production, Real-time Instrumentation and Visualization. The programme consisted of 48 one-hour lectures and 20 hours of tutorials, with 19 speakers. 65 students, of 21 different nationalities and coming from 20 countries, attended.

The 21st CERN School of Computing will take place in Funchal, Madeira, Portugal, from 6 - 19 September 1998, organized in collaboration with LIP, Lisbon. Its themes will be: Intelligent Monitoring and Control; Petabyte Storage (data bases); Agent and Distributed Computing Technology; and Software Evolution.

It is open to postgraduate students and research workers with a few years' experience in elementary particle physics, computing or related fields. The 80 or so participants will be selected mostly from CERN Member States or from laboratories closely associated with CERN, but a few may come from CERN non-Member States.

Applications should be sent to Miss Jacqueline Turner, School of Computing, CERN, 1211 Geneva 23, Switzerland phone +41 22 767 5049; fax: +41 22 767 7155; e-mail:

Computing.School@cern.ch  
<http://www.cern.ch/CSC/> The application deadline is 15 May 1998

## HEIDELBERG Debut of GENIUS

With particle physics is making extreme demands on future accelerators, non-accelerator physics (propagator physics) provides a complementary approach.

Accelerators provide high interaction rates, but are energy limited, while passive experiments have low rates and less energy restrictions.

The recent Castle Ringberg 'Beyond the Desert' meeting (November, page 16) saw the launch of the GENIUS (Germanium in Nitrogen Underground Setup) proposal for a new double beta decay and dark matter search by H.V. Klapdor-Kleingrothaus, head of the Heidelberg specialist double beta decay group.

The idea is to use one ton, or more, of 'naked' enriched germanium-76 detectors in a shielding of liquid nitrogen in a tank of about 10m height and diameter. This should probe the neutrino mass down to  $10^{-2}$  or  $10^{-3}$  eV, and test various variants of supersymmetric models, the atmospheric neutrino problem and some aspects of the solar neutrino problem.

Aside from neutrino physics, it would allow exploration of such ideas as leptoquarks, R-parity breaking and conserving supersymmetry, compositeness, left-right symmetric models etc. in the multi-TeV region.

For cold dark matter, it would cover

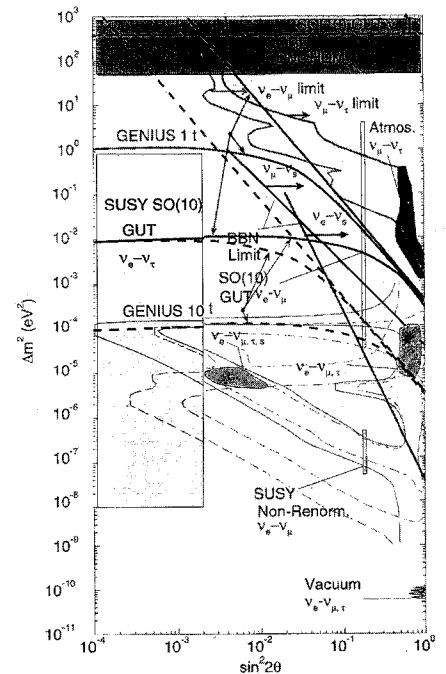

the whole parameter space of supersymmetric models for neutralinos as dark matter and thus also ranges in which supersymmetry detection in collider experiments has some problems. If CERN's LHC were to observe supersymmetry, it would be fascinating to show the existence of neutralinos as dark matter.

For its GENIUS proposal, the Heidelberg group has demonstrated the feasibility of germanium detectors operating in liquid nitrogen.



# Physics monitor

*Participants in the recent Topics in Astroparticle and Underground Physics (TAUP'97) workshop outside the Italian Gran Sasso laboratory.*

## Cosmology below ground

The Topics in Astroparticle and Underground Physics (TAUP) workshop reflects the growing importance of this field and its link with traditional particle physics. TAUP'97, fifth in the series, was held at the Italian Gran Sasso Laboratory from 7 - 11 September. A report on the neutrino aspect of the workshop appeared last month, and this month James Gillies' follow-up piece considers cosmology and cosmic rays.

Cosmology was the first day's topic, and after a brief introduction from workshop chairman Piero Monacelli of l'Aquila, Chicago's David Schramm set off in religious vein. Attempts to define the age of the Universe, he said, began in 1654 when Archbishop Usher counted biblical 'begats' to conclude that the Universe began at 4 p.m. on 22 October 4004 BC. Today's determinations may be more scientific, contended Schramm, but they are still subject to the same high precision with large systematic errors. Things, however, are improving. Recent measurements of the Hubble constant, which measures the Universe's expansion as a function of distance, have begun to converge to a value around 60 kilometres per second per megaparsec, dating the Universe at around 12 gigayears.

Another burning question in cosmology is the matter density of the Universe. It is widely known that the Universe contains substantial amounts of matter undetectable by conventional astronomy, but is this dark matter enough to cause gravitational collapse, or will the



Universe expand forever? Theory suggests that the matter density will have some critical value such that the expansion stops when time reaches eternity. Recent measurements show that the density of galactic clusters is about a quarter of this critical value. Extrapolating from these measurements, Schramm inferred that most dark matter must be non-baryonic and that if the matter density has precisely the level needed to stop indefinite expansion, then dark matter must have hot (fast-moving) and cold (slow-moving) components, since most cold dark matter will be in clusters.

Saclay's Michel Spiro concentrated on the search for baryonic dark matter in the form of MACHOs, Massive Astrophysical Compact Halo Objects, at the periphery of our galaxy. These could be brown dwarfs, neutron stars, or black holes. Several candidates have been found in the direction of the Magellanic clouds, suggesting that up to half of our galaxy's halo could be made up of MACHOs.

Non-baryonic dark matter searches were summarized by Lars Bergstrom

of Stockholm. Neutrinos are a possibility, but they could not have seeded galaxy formation, and Pauli's exclusion principle prevents them from being packed tightly enough to explain the amount of dark matter in dwarf galaxies. Neutrinos, therefore, are unlikely to account for more than about a tenth of dark matter. The most popular candidate is supersymmetry, the elegant and appealing theory proposed to link particles of matter with the particles which carry forces between them. Supersymmetry predicts a range of new particles which are the subject of intensive searches at both passive and accelerator laboratories.

Many supersymmetric particle searches look for neutrinoless double beta-decay in germanium. This process, so far undetected, whereby two electrons are emitted from a nucleus without accompanying neutrinos, could be mediated by supersymmetric particles. Heidelberg's Laura Baudis described a new germanium experiment which will better its predecessors by improving background suppression. The Heidelberg team is also drawing



# UNE HAUTE IDÉE DE L'ENTREPRISE

À 10 minutes de l'aéroport international de Genève, au carrefour des réseaux autoroutiers F/CH/D/I, près de deux gares TGV, à proximité du prestigieux CERN.

**propose sur 40 hectares :**  
des parcelles de terrains viabilisées (achats ou location)  
des bureaux et des bâtiments mixtes  
une pépinière d'entreprises  
des services spécifiques d'assistance aux entreprises pour une implantation régionale et pour des relations avec le CERN  
un Bureau de Rapprochement des Entreprises agréé par la CEE.

**CONTACT:**  
**SYNDICAT INTERCOMMUNAL D'ACTIVITÉ DU PAYS DE GEX**  
50, rue G. Eiffel - BP 104  
F-01632 Saint-Genis-Pouilly  
Tél. (033) 04 50 42 20 00 - Fax (033) 04 50 42 20 20  
E-mail: [bregex@leman.com](mailto:bregex@leman.com)  
internet: <http://www.leman.com/~bregex>

## LE TECHNOPARC - PAYS DE GEX -

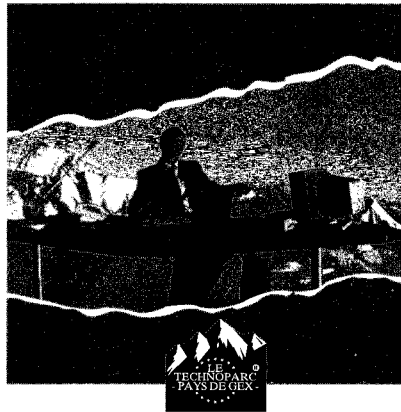

**proposes 100 acres (40 ha) of equipped site with :**  
pieces of land (purchasing or renting)  
offices spaces  
activity buildings  
incubator  
Business Corporation Center agreed by CEE.

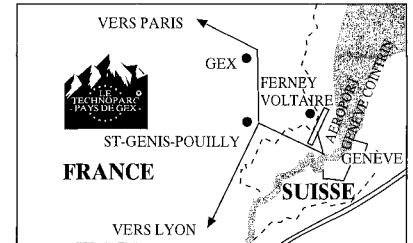

## POSTE DE PROFESSEUR L.A.L. ORSAY

Université de Paris-Sud  
Laboratoire de l'Accélérateur Linéaire

**Un poste de Professeur expérimentateur en Physique des Particules** sera ouvert au Concours début 1998. Le physicien recruté devra prendre des responsabilités importantes dans le programme ATLAS au LAL.  
Les candidats intéressés sont priés d'envoyer un curriculum vitae à :

Jacques LEFRANÇOIS  
Directeur du L.A.L.  
Bâtiment 200 - Université de Paris-Sud  
F 91405 ORSAY Cedex

E-mail : [lefrancois@LAL.IN2P3.FR](mailto:lefrancois@LAL.IN2P3.FR)

## Ludwig-Maximilians-Universität München

in der Fakultät für Physik ist ab 1. April 1997 eine

### Professur (C 3) für Theoretische Physik

zu besetzen.

Der Forschungsschwerpunkt des Bewerbers / der Bewerberin sollte auf dem Gebiet der Phänomenologie der Elementarteilchen liegen. Zu den Aufgaben gehört die Vertretung des Faches in Forschung und Lehre. Die Bereitschaft zu einer Zusammenarbeit mit Forschergruppen an der Sektion Physik ist erwünscht, insbesondere auf dem Gebiet der experimentellen Hochenergiephysik.

Einstellungsvoraussetzungen sind abgeschlossenes Hochschulstudium. Promotion und Habilitation oder gleichwertige Qualifikation sowie pädagogische Eignung.

Bewerber und Bewerberinnen dürfen das 52. Lebensjahr zum Zeitraum der Ernennung noch nicht vollendet haben.

Die Universität München ist bestrebt, den Anteil der Professorinnen zu erhöhen. Qualifizierte Wissenschaftlerinnen werden deshalb besonders aufgefordert, ihre Unterlagen einzuziehen.

Bewerbungen sind mit den üblichen Unterlagen (Lebenslauf, Zeugnisse, Urkunden, Schriftenverzeichnis) bis 05.01.1998 beim Dekanat der Fakultät für Physik der Ludwig Maximilians Universität München, Schellingstraße 4, 80799 München, einzureichen.

Three scenarios for the future of the Universe. The current expansion rate, as measured by the Hubble constant,  $H_0$ , is marked. If the Universe is denser ( $\Omega > 1$ ) than some critical value, it will eventually collapse in a big crunch. If it is less dense, it will continue to expand forever.

up plans for Genius, a 1 ton detector which, said Baudis, would show definitively whether supersymmetric particles exist as well as being able to measure neutrino masses down to 0.01 eV).

A new generation of cryogenic detectors, able to measure tiny energy depositions, is set to make its mark on dark matter searches as well as many other aspects of underground physics, said Oxford's Norman Booth. The large number of related talks which followed lent weight to his case. Dan Akerib from Case Western Reserve described the Cryogenic Dark Matter Search experiment currently testing prototypes at Stanford and preparing to install a full scale detector in Minnesota's Soudan mine. The French experiment Edelweiss, being installed in the Frejus laboratory, was presented by Philippe di Stefano of Saclay, whilst Noel Coron of Orsay presented Rosebud, an experiment due to start up later this year at Canfranc in the Pyrenees. The CRESST collaboration was presented by Ludwig Zerle of the Max Planck Institute in Munich. CRESST's 262 gram sapphire crystal detector, cooled to 15 millikelvin, is currently under test at Gran Sasso.

Two innovative cryogenic approaches were described by Bern's Klaus Pretzl and Sheffield's Dan Tovey. Pretzl discussed the Orpheus experiment to be installed at Bern's underground laboratory next year. Orpheus relies on superheated superconducting granules. Magnetic field lines normally run round the granules, but when a heavy particle hits a granule causing it to lose its superconductivity, the field lines pass through it, causing a measurable change in magnetic flux. In the Caspar experiment, destined for the

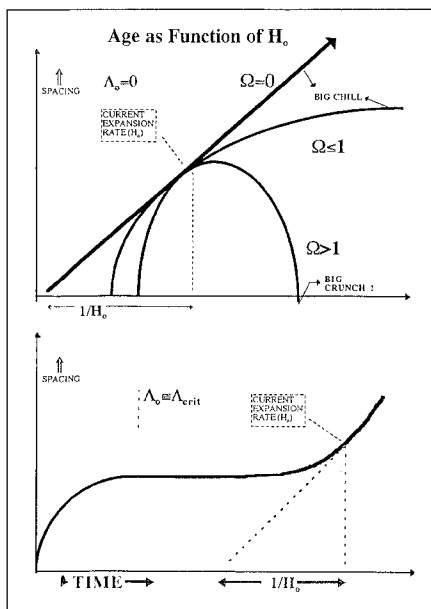

Boulby mine in Northern England, grains of inorganic scintillator are suspended in a gel of organic scintillator. As explained by Tovey, recoils from heavy particles are contained in the grains whereas electron recoils are not. This allows discrimination on pulse shape.

Satellite-borne experiments were covered by Columbia's Marc Kamionkowski and Florence's Piero Spillantini. Kamionkowski discussed NASA's MAP and ESA's Planck programmes which will improve on the COBE measurements of the tiny irregularities in the cosmic microwave background. MAP is due to be ready by 2001 or 2002, whereas Planck is scheduled for launch in 2003. Spillantini described two experiments, AMS and Pamela, which will search for charged antiparticles in primary cosmic radiation. Such antiparticles could either result from the existence of large amounts of antimatter in the Universe, or be produced in the annihilation of supersymmetric

particles in space. AMS will fly briefly in 1998 on the space shuttle before being installed in the space station. Pamela, developed from the Wizard high altitude balloon experiments, is scheduled to be launched from Baikonur in 1999.

Wuppertal's Heinrich Meyer discussed high energy gamma rays originating from active galactic nuclei and supernova remnants. These are thought to be synchrotron radiation from electrons orbiting in the magnetic field of their parent object. But if this is the case, said Meyer, then electrons of  $10^{17}$  eV would be needed to account for the 70 TeV events seen. No one, he said, has yet given a satisfactory quantitative explanation of such high energies.

Gran Sasso's Veniamin Berezhinsky speculated on the origin of cosmic rays with energies over  $10^{19}$  eV. There are as many models as events, he said, ranging from astrophysical shock waves to ultra heavy dark matter particles. The only thing which seems certain is that unless the primaries are iron nuclei, then these particles come from beyond our galaxy.

Tsvi Piran of Jerusalem's Hebrew University traced the detective story which seems to have resolved the enigma of gamma ray bursts. These short bursts of photons were discovered by chance in the 1960s by military satellites. They originate outside the solar system and, until recently, were not correlated with any other signal. One possible explanation, developed by Piran and others, suggests that gamma ray bursts come from some kind of extragalactic fireballs, and predicts an x-ray aftershock. In February this year, a satellite observed just such an event, strongly supporting Piran's interpretation (July, page 16). What

exactly are these fireballs? Piran's favoured candidate is merging binary neutron stars.

CERN's Carlo Rubbia concluded the workshop with a personal look at the future. Although accelerators will do great physics, according to Rubbia "that will not be enough". Rubbia proposes a new methodology, saying that just as beta decay told us much about W and Z particles without requiring high energy accelerators, so proton decay could tell us about physics at the unification scale. In a succinct paraphrasing of Heisenberg's uncertainty principle, Rubbia pointed out his view of the way forward; "If you don't have the energy", he said, "you have to have patience."

The next TAUP meeting will be held at Saclay, France, in 1999.

## Overview of underground physics at Gran Sasso

*The Italian Gran Sasso laboratory, one of the world's leading sites for underground physics, was born in 1980 following a suggestion from Antonino Zichichi. A new motorway was to be built under the Gran Sasso massif, and it seemed logical to build the laboratory at the same time. In 1982 construction began, and in 1988, the laboratory opened.*

*The Laboratory consists of three large halls connected by a network of tunnels and service areas underneath 1400 metres of rock. Along with low levels of natural*

*radioactivity, this makes it an ideal place for studying neutrino physics and rare processes.*

*Gallex is one of Gran Sasso's most important experiments. Running from 1991 to 1997, it made pioneer measurements of neutrinos from the main proton-proton fusion reaction in the Sun. Gallex results confirm evidence from other experiments that fewer solar neutrinos reach the Earth than expected. New experiments, the Gallium Neutrino Observatory, Borexino, and Icarus will extend the studies Gallex began, bringing a greater understanding of the reactions taking place at the heart of the Sun.*

*MACRO is colossal electronic detector patiently studying high energy cosmic rays in a hunt for exotic particles such as magnetic monopoles. MACRO, along with another experiment, LVD, is also on the look out for bursts of neutrinos originating from supernovae.*

*Smaller experiments like the cryogenic dark matter search, CRESST, and an accelerator experiment measuring the cross-sections of reactions which happen at the Sun's core also benefit from Gran Sasso's low radiation environment. With two new experimental halls and a possible neutrino beam from CERN, Gran Sasso has a bright future for many years to come.*

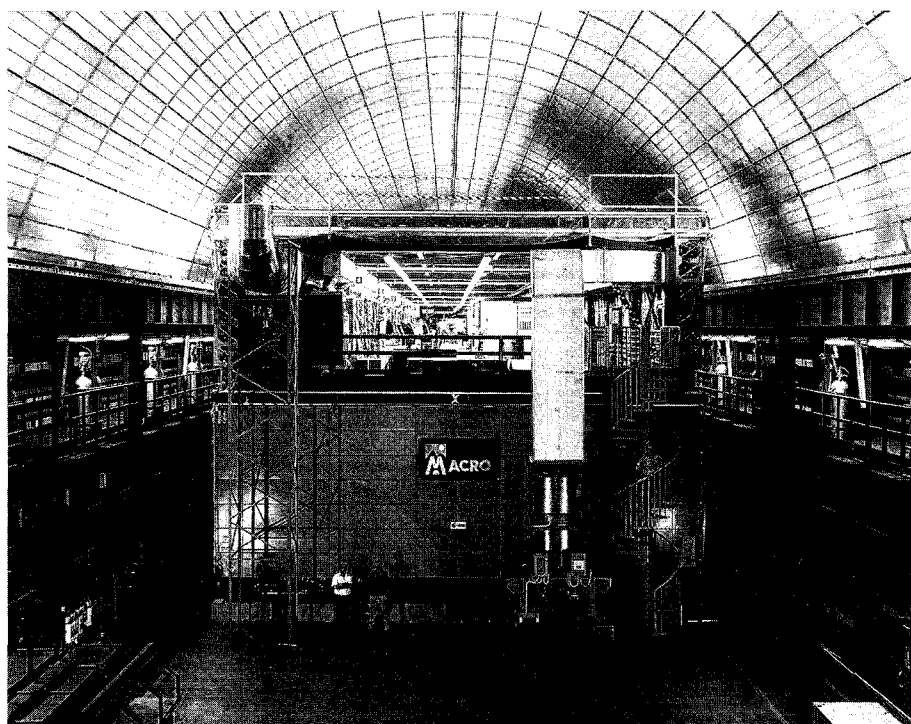

*Gran Sasso's Macro experiment has been keeping a watchful eye open for magnetic monopoles since 1989.*

IOWA STATE UNIVERSITY  
DEPARTMENT OF PHYSICS AND ASTRONOMY  
TENURE-TRACK ASSISTANT PROFESSOR  
Experimental High-Energy Physics

The Department of Physics and Astronomy at Iowa State University invites applications for a tenure-track faculty position in experimental high-energy physics to begin August, 1998. Requirements include a Ph.D. and record of research accomplishments in experimental particle physics. Effective teaching at both the undergraduate and graduate level will be expected. Current high-energy physics research at ISU is centered in two programs: one at hadron collider facilities (D0 at Fermilab and CMS at the CERN LHC) and the other at electron-positron collider facilities (DELPHI at LEP and BaBar at SLAC). The new faculty member is expected to join one of these programs. Other related research at ISU includes particle astrophysics at the Whipple gamma-ray observatory and studies of relativistic heavy-ion collisions at RHIC (the PHENIX collaboration).

Applicants should send a letter of application and a resume which includes a list of publications and names of references, and arrange for three letters of recommendation to be sent to:

**Experimental High Energy Search Committee**  
c/o Ms. Erlene Mooney  
Department of Physics and Astronomy  
Iowa State University  
Ames, IA 50011-3160

No formal application materials will be accepted by e-mail. Applications will be accepted until January 24, 1998 or until the position is filled. Iowa State University is an equal-employment-opportunity/affirmative-action employer. Women and individuals from minority groups are encouraged to apply. Further information about the department may be found at <http://www.public.iastate.edu/~physics/>.



UNIVERSITY OF  
OXFORD

in association with Lady Margaret Hall

Department of Physics

**University Lectureship in  
Experimental Particle Physics**

Applications are invited for the above post which is available from 1 October 1998. Oxford University has a wide ranging research programme in particle physics and particle astrophysics. We are heavily involved in preparations for the ATLAS and LHC-B experiments, while continuing strong participation in the DELPHI experiment at LEP and the ZEUS experiment at DESY. The particle astrophysics activities include the current Soudan 2 experiment in the USA and preparations for the MINOS neutrino oscillation experiment at that site, as well as the Sudbury Neutrino Observatory in Canada, the CRESST dark matter search in Italy, and further development of cryogenic detectors for dark matter searches and other applications such as X-ray astronomy. We are also exploring the possibilities of neutrino astronomy with ANTARES. The appointee would be expected to participate in the future development of this programme and possibly in additions to it.

The stipend is according to age on the University Lecturer scale £16,045 - £29,875 per annum. The successful candidate may be offered a tutorial fellowship by Lady Margaret Hall in which case the combined university and college salary would be according to age on a scale up to £35,754 per annum. Additional college allowances may be available. Further particulars of the duties and emoluments of both the university and college posts may be obtained from the Deputy Administrator, Department of Physics, Nuclear & Astrophysics Laboratory, Keble Road, Oxford, OX1 3RH, email, p.dobbs1@physics.ox.ac.uk.

Applications including a statement of research interests and teaching experience, curriculum vitae, list of publications and the names of three referees should be mailed to the Deputy Administrator at the above address to arrive no later than 31 January 1998. The referees should be asked to send letters of reference directly to Professor Susan Cooper, Head of Particle & Nuclear Physics at the same address to arrive by the closing date. It is expected that short-listed candidates will be interviewed in Oxford in March 1998. Applicants are asked to provide an email address, fax or telephone number where they can be contacted.

The University is an Equal Opportunities Employer.



ÉCOLE POLYTECHNIQUE  
FÉDÉRALE DE LAUSANNE

For its Department of microengineering, the Swiss Federal Institute of Technology Lausanne (EPFL) invites applications for a full professor position:

**PROFESSOR IN BIOMEDICAL OPTICS**

Applicants should have a university education in science or engineering, several years of recent research and development experience in the field of biomedical photonics, and well established collaborations with medical research groups. Priority will be given to candidates who can give evidence of original and creative activity in the industrial or academic sphere and who are ready to develop and maintain collaboration with industries. The candidate should possess a good leadership as well as a marked interest and talent for teaching at the undergraduate and graduate level. In particular, he/she should have a personal vision in his/her field and enjoy to be a mentor to students and young researchers.

**Deadline for applications: February 15, 1998.**  
Start date: as mutually convenient.

Applications from women are particularly welcome. For further information, please write to:  
*Présidence de l'Ecole polytechnique fédérale de Lausanne,  
CE-Ecublens, CH 1015 Lausanne, Suisse*

The Max-Planck-Institut für Physik,  
München, offers the postdoc-position of an  
**Experimental Physicist (Ph.D.)**

to participate in the experiment HEGRA (High Energy Gamma Ray Astronomy), which is carried out at La Palma, Spain, to investigate ultra-high energetic cosmic rays. In particular, his/her work will concentrate on the data analysis, but participation in the measurements at La Palma is also expected. Furthermore, the candidate should participate in the development of new detectors for very high energy gamma-ray astronomy, such as a 17 m  $\varnothing$  air Cherenkov telescope. Candidates should have broad experience in complex physics evaluations and analysis programs and should be able to carry out scientific tasks independently.

The position is available as of January 1998, and the contract will initially be limited to three years with the possibility of an extension.

Applications, together with a curriculum vitae, a list of publications and three references, should be sent as soon as possible to

Prof. N. Schmitz  
Max-Planck-Institut für Physik  
Föhringer Ring 6  
80805 München  
Germany

## WORKSHOP Radiofrequency superconductivity

A quarter of a century after the first machine based on superconducting radiofrequency (RF) cavities accelerated its first beam at Stanford's High Energy Physics Laboratory, the 8th biennial workshop on RF superconductivity was held from 6-10 October at Abano Terme (Italy). The technique has come a long way since then.

After opening talks on basic superconductivity theory, presentations covered more general topics as well as laboratory developments. For instance RF application of high temperature superconductors seems to be going well in commercial applications where ready-made filters with incorporated cryocooler can already be bought off the shelf. However, machines equipped with accelerating cavities using high temperature superconducting materials still seem to be out of reach.

Laboratory and review talks discussed problems of daily accelerator operation and highlighted technical achievements. New surface analysis techniques will improve understanding and hopefully lead to defeating the old enemies: contamination layers, field emitters and defects, whether on the surface or hidden in the material.

Furthermore, intense studies improve the understanding of sputtered superconducting niobium layers, while production modifications improve performance. The prospects of other thin film superconductors, such as NbTiN (niobium titanium

nitride) or Nb<sub>3</sub>Sn (niobium-tin), were also discussed.

The number of operational machines increases steadily. Munich's unique superconducting Triton cyclotron (see page 15) with its huge 170 MHz lead-plated leap-frog cavities announced its first beam, while the Darmstadt S-Dalinar has logged 16000 physics beam hours, its cavities being upgraded for higher performance.

Several heavy ion accelerators reliably deliver beam to physicists and a radioactive beam facility is in preparation at Argonne's ATLAS machine. Two years ago the then-new CEBAF machine at the Jefferson Laboratory, Virginia, had provided 800 MV per passage to the beam, then the highest 'superconducting voltage' available. Meanwhile this machine has accumulated more than 3 million operational cavity-hours without real problems, showing the impressive reliability of this technology. In test runs the average cavity gradient has even improved to 1200 MV per passage, opening the door to higher energies.

Since the last workshop, CERN's LEP2 has made its debut, and its 240 installed superconducting cavities hold the record for a 'superconducting voltage' - about 2.3 GV (the existing copper cavities bring the total voltage to 2.6 GV). Its smooth running provides more proof that superconducting RF cavities have become standard accelerator equipment (see page 8).

The TESLA project with its 20,000 superconducting cavities at a field of 25 MV/m (October, page 12) aims for the blue riband of superconducting voltage. With the collaboration of many laboratories from all over the world, a demonstration is well under

*CESR-B superconducting single cell cavity at 500 MHz made from bulk niobium by the European Accel concern. The front beam tube is fluted to trap the fundamental mode but let higher order modes leak out to a warm ferrite absorber. Behind is the wave guide coupler for the main power input. (Accel, of Bergisch-Gladbach, close to Cologne, Germany, is the survivor of the ex-Interatom Siemens division, bought up by key personnel and now autonomous.)*

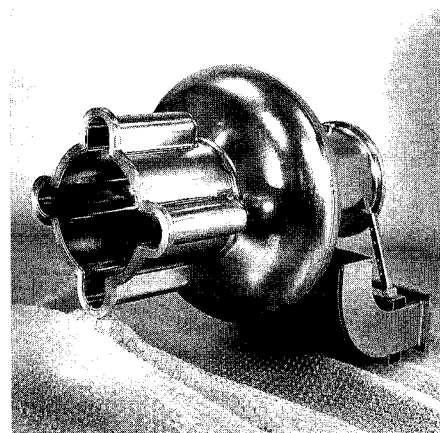

way at the test facility (TTF) at DESY. As well as showing the feasibility of the TESLA technology prior to project approval, it will also be exploited in a free electron laser.

Large installations such as CEBAF and LEP2 have already required industrial series production methods, pushing down cost and at the same time assuring thorough quality control. This becomes crucial for TESLA. For example a method using eddy current scanning of niobium sheets has been developed to detect inclusions (like tantalum clusters) below the metal surface prior to fabrication. A great step towards cheaper cavity production was made at the Legnaro host laboratory, where entire multicell cavities of the TESLA type can be spun, without welding, using a dismountable mandrel.

One common difficulty for all high current machines, the transport of high RF power into the cold cavities, seems to be largely mastered. Multipacting problems in the cooled areas of the LEP2 couplers have been overcome by thorough preparation of the couplers during production and processing and finally by the application of a DC bias voltage of 2-3 kV. There have been no operational problems with the

power couplers. At CERN the coupler performance was demonstrated on a dedicated cold cavity where 500 kW (CW) at 352 MHz were transmitted to a pair of standard LEP couplers. At KEK, Japan, several pairs of couplers on a test stand at 508 MHz reached 800 kW (CW) power transport without DC bias. First tests with different designs of a TESLA coupler look promising, couplers having been exposed up to 210 kW in CW.

Besides the two traditional customers for superconducting cavities, electron accelerators or storage rings (high relativity beta) and slower heavy ion (low beta) accelerators, another customer has appeared: high intensity proton linacs used for various neutron spallation sources. These will need superconducting cavities with lower beta, similar in shape to the present high beta ones but with shorter cells. This presents new technical challenges for mechanical stability and thin film production of niobium-sputtered cavities.

Particle factories, such as those at KEK or Cornell, need classical high beta cavities, but the higher order modes (HOM) become a problem and cavities with special internal absorbers or 'fluted' cut-off tubes have been built by industry.

Future applications were described in the final morning session, including Carlo Rubbia's presentation of his energy amplifier/nuclear waste incinerator and Björn Wiik's overview of plans for the TESLA machine.

The Abano Terme workshop was organized by INFN's Legnaro Laboratory under the chairmanship of Vincenzo Palmieri and attracted a record 220 participants from 16 countries - including representatives from industry. The next workshop will

be in 1999 at Santa Fe, New Mexico, under the chairmanship of Brian Rusnak of Los Alamos.

*By Joachim Tückmantel*

## Book received

*Niels Bohr - Collected Works, Volume 7, Foundations of Quantum Physics II (1933-1958), Edited by Jørgen Kalckar, Elsevier, ISBN 0444898921, \$343.75*

Prepared under the auspices of the Niels Bohr Archive, this monumental and painstakingly prepared volume is the second collection (after Volume 6) of Bohr material on the Foundations of Quantum Mechanics. Part I of Volume 7 presents the extension of the analysis of complementary relationships to the foundations of relativistic quantum mechanics, while Part II covers further analysis of basic issues in Bohr's continual quest for deeper insight. Part III includes some gems of correspondence with his contemporaries (Einstein, Heisenberg, Klein, Kramers, Pauli, Rosenfeld, Schrödinger, Weisskopf). A treasure of material for Bohr scholars.

## External correspondents

- Argonne National Laboratory, (USA)  
**D. Ayres**
- Brookhaven, National Laboratory, (USA)  
**P. Yamin**
- CEBAF Laboratory, (USA)  
**S. Corneliusen**
- Cornell University, (USA)  
**D. G. Cassel**
- DESY Laboratory, (Germany)  
**Ilka Flegel, P. Waloschek**
- Fermi National Accelerator Laboratory, (USA)  
**Judy Jackson**
- GSI Darmstadt, (Germany)  
**G. Siegert**
- INFN, (Italy)  
**A. Pascolini**
- IHEP, Beijing, (China)  
**Qi Nading**
- JINR Dubna, (Russia)  
**B. Starchenko**
- KEK National Laboratory, (Japan)  
**A. Maki**
- Lawrence Berkeley Laboratory, (USA)  
**B. Feinberg**
- Los Alamos National Laboratory, (USA)  
**C. Hoffmann**
- NIKHEF Laboratory, (Netherlands)  
**Margriet van der Heijden**
- Novosibirsk Institute, (Russia)  
**S. Eidelman**
- Orsay Laboratory, (France)  
**Anne-Marie Lutz**
- PSI Laboratory, (Switzerland)  
**P.-R. Kettle**
- Rutherford Appleton Laboratory, (UK)  
**Jacky Hutchinson**
- Saclay Laboratory, (France)  
**Elisabeth Locci**
- IHEP, Serpukhov, (Russia)  
**Yu. Ryabov**
- Stanford Linear Accelerator Center, (USA)  
**M. Riordan**
- TRIUMF Laboratory, (Canada)  
**M. K. Craddock**



The College Of  
**WILLIAM & MARY**

**FACULTY POSITION**

The William & Mary Physics Department invites applications for a tenure-track position in experimental nuclear or particle physics. The position should start in the fall of 1998, and would be at the entry level of assistant professor unless exceptional circumstances warrant appointment at a more senior level. The Department has a strong commitment to Jefferson-Lab-related activities. In addition, its nuclear and particle groups are engaged in research programs at BNL, MIT-Bates, SLAC, TRIUMF and other labs. The Department has 30 full-time faculty, approximately 50 graduate students, and a substantial number of undergraduate majors who actively participate in its various research programs. The candidate would be expected to initiate and maintain a strong research program in experimental nuclear or particle physics including work at Jefferson Lab, to seek external funding, and to teach well at both the undergraduate and graduate levels. Applicants should send a current resume and a summary of research interests. In addition, they should arrange to have three or four letters of recommendation sent on their behalf. All correspondence should be mailed to :

**Chair, Nuclear/Particle Search Committee**  
Department of Physics, PO Box 8795  
College of William & Mary  
Williamsburg, VA 23187-8795, USA  
<NPsearch@physics.wm.edu>  
<www.physics.wm.edu>

Screening of applicants will begin on 5 January 1998 and continue until the position is filled. *The College of William & Mary is an Equal Opportunity/Affirmative Action university. Members of under-represented groups are strongly encouraged to apply.*

**STOCKHOLM UNIVERSITY**  
**FYSIKUM**

The Department of Physics at the Stockholm University has opened a

**Research Assistant Position in Experimental  
Astroparticle Physics**

The research group in experimental astroparticle physics at Stockholm University is involved in the AMANDA detector for cosmic high energy neutrinos. The scientific goals include the search for neutrinos from point sources in the Universe and indirect searches for dark matter candidates.

The ten string AMANDA-B10 detector, at 2000 metres depth in the South Pole glacier, is taking data continuously since February 1997. The first neutrino candidates have recently been reconstructed and the experiment is in an intensive development phase.

The AMANDA detector will in the coming 3 years be upgraded to AMANDA-2 and a cubic kilometres (ICECUBE) detector for the future is under investigation.

The candidate should have completed a Ph.D. in Physics within the last 5 years. Experience in experimental high-energy physics or astroparticle physics is desired.

The appointment will initially be limited to two years with a possible extension to four years or, with 20% teaching duties, to five years.

Applicants should send their curriculum vitae, a short description of current research and teaching experience, a list of relevant publications as well as one copy of each, copies of university degrees and three letters of recommendations before the **2nd of February 1998** to Stockholm University, Personnel Division, Registrar, S-106 91 Stockholm, Sweden. The reference number for the position is 614-2656/97. The fax number is +46 8 612 5960.

For additional information, please contact Prof. Per Olof Hulth, e-mail: hulth@physto.se, phone +46 (0) 8 1646633 or Dr. Ariel Goobar, e-mail: ariel@physto.se, phone +46 (0) 8 164725, fax +46 (0) 8 347817.

**POSTDOCTORAL  
FELLOWSHIP IN HIGH  
ENERGY NUCLEAR  
PHYSICS**

The Nuclear Science Division of the **Ernest Orlando Lawrence Berkeley National Laboratory** has an opening for a postdoctoral physicist in the area of experimental high energy nucleus-nucleus collisions. The appointment is for a term of two years with the possibility of renewal. The successful candidate will have a Ph.D. in nuclear or particle physics, and is expected to participate in the STAR activities of the Relativistic Nuclear Collisions (RNC) Group with residency at Berkeley and/or Brookhaven.

The RNC Group plays a leading role in the STAR experiment at the Relativistic Heavy Ion Collider (RHIC) at Brookhaven with responsibility for the construction of the central detector (TPC) and software development, and has active experimental programs at the CERN SPS (NA49) and at the Brookhaven AGS (E895).

Applicants are requested to submit a curriculum vitae (indicating Job #) and a list of publications. In addition, they should arrange for three letters of reference to be sent to: **H.G. Ritter, LBNL, Job #NSD5527/JCERN, MS 50A-1148, One Cyclotron Road, Berkeley, CA 94720**, or e-mail to: **HGRitter@LBL.gov**. The position is open until filled. Berkeley Lab is an affirmative action/equal opportunity employer committed to the development of a diverse workforce.



**Research Associate Position  
High energy Physics  
The Ohio State University**

The Experimental High Energy Physics group at the Ohio State University invites applications for a postdoctoral research associate position with our CLEO program at CESR. In addition to our ongoing data analysis effort in heavy flavor physics, we are also involved with the CLEO III upgrade program where we have major responsibilities for the design and implementation of the Silicon Vertex Detector and data acquisition system. Interested candidates should send a letter of application, vitae, list of publications, and three letters of recommendation to Professor K.K. Gan, The Ohio State University, Department of Physics, 174 West 18th Ave., Columbus, Oh 43210-1106. *The Ohio State University is an equal opportunity employer and we actively encourage applications from women and minority candidates.*

# People and things

Knud Henrik Hansen 1927 - 97

---

## On people

---

Among the recipients of prizes from the French Physical Society this year were: experimentalist Roy Aleksan of Saclay, who received the Joliot-Curie Prize; nuclear physicist Jean-Paul Blaizot of Saclay, who received the Jean Ricard Prize; and theorist Alexandre Grossman of Luminy, Marseille, who received a special prize.

CERN Director General Chris Llewellyn Smith has been elected Foreign Fellow of the Indian National Science Academy.

Ugo Amaldi of Milan and CERN has received the award of Doctor Honoris Causa of the University Claude Bernard Lyon 1 in the context of activities to celebrate the centenary of the discovery of radioactivity.



Distinguished Indian theorist Amitava Raychaudhuri of Calcutta receives the prestigious Shanti Swarup Bhatnagar Award, given to young Indian scientists for work mainly done in India.

---

## Knud Henrik Hansen 1927 - 97

---

One of the pioneers and leaders of Scandinavian particle physics, Knud H. Hansen, died on October 22, a few days after his 70th birthday.

He joined the Niels Bohr Institute, then called the Institute for Theoretical Physics, Copenhagen in 1956. As a student, he had already begun work with Jørgen K. Bøggild's cosmic ray group, eventually becoming its leader in 1965 and remaining so until retiring in 1992 due to health problems. With CERN underway, he was a driving force in the formation of the influential Scandinavian Bubble Chamber Collaboration. He and his group made important contributions to a number of large international collaborations.

He enjoyed investigating the high energy frontier and welcomed the opportunities presented by CERN's ISR. There he was actively involved in the formation of the British-Scandinavian Collaboration, among the first to study high transverse momenta phenomena, and later in the Axial Field Spectrometer

---

At the inauguration of the first 'Greece at CERN' industrial expo, Andromachi Tsirou (left) explains the Delphi experiment to Emmanuel Frangoulis, Secretary General and Vice Minister, Greek Ministry of Industry. Between them is Emmanuel Floratos, Greek delegate to CERN Council. (Photo CERN HI 6.10.97)



Collaboration, where these studies were extended to jets.

In the mid-80s, his group joined Delphi at LEP, but while he gave this his full support, he was more interested in the new opportunities of relativistic heavy ion collisions and later joined the NA44 collaboration, where he remained a member also after his retirement.

Knud Hansen was excited by new investigations and transmitted this excitement to his students and collaborators. With a deep respect for fundamental physics, he was cynical of superficial fashion. He constantly strived to instil in his students an appreciation of the 'real' physics objectives.

Knud Hansen also played an important role in the formation of the NBI theoretical high energy group through timely support and encouragement of young physicists.

He became a much respected director of the Institute in 1985 and remained so until his retirement. He represented Denmark in the CERN Council for a short period around 1980. In 1983, he was made an honorary doctor at Lund.



POSTDOCTORAL RESEARCH ASSOCIATE  
EXPERIMENTAL HIGH ENERGY PHYSICS  
IOWA STATE UNIVERSITY

The Ames High Energy Physics group at Iowa State University has an immediate opening for a postdoctoral associate to join its experimental program. Our group is currently designing, building and testing electronics for the BaBar experiment at the SLAC Asymmetric B-Factory. The new postdoctoral associate will be stationed at SLAC as part of this program and should have experience in both hardware (electronics) design, online software systems and data analysis. Experience with C++ is desirable. BaBar is scheduled for installation in 1999 and data collection should begin shortly thereafter. The main physics goals of BaBar are measurements of CP-violation in the b-quark sector, heavy quark physics studies to both measure CKM matrix elements and to overconstrain the unitary triangle.

Other activities of our group include ongoing participation in the DELPHI experiment at the CERN LEP collider and the testing and evaluation of high speed digitizing electronics. Additional information is available on our web page: [www.public.iastate.edu/~alhep](http://www.public.iastate.edu/~alhep).

Candidates should have a Ph. D. in experimental particle physics and have a strong interest in software development and data analysis. Applications including a current vita, list of publications and three letters of reference should be sent to:

**Professor Eli I. Rosenberg**  
Department of Physics & Astronomy  
Iowa State University  
Ames, Iowa 50011-3160 USA

or via email to: [rosenberg@hep.isuhep.iastate.edu](mailto:rosenberg@hep.isuhep.iastate.edu)

Applications should reach us as soon as possible and will only be considered after December 31, 1997 if the position is still unfilled. Iowa State University is an affirmative action/equal opportunity employer. Minorities and women are encouraged to apply.



**BEAM INSTRUMENTATION ENGINEER**  
(Position #AR3106)

The Thomas Jefferson National Accelerator Facility (Jefferson Lab) is seeking a senior Beam Instrumentation Engineer for a position in the Electronics and Instrumentation Development Group. The successful candidate will be responsible for the design, development, implementation, and project leadership of various electronic subsystems in the CEBAF accelerator and Free Electron Laser (FEL). The individual will provide job direction to junior engineers and technicians and communicate with accelerator physicists and other engineers to improve performance of the accelerator and FEL. The minimum qualifications for this position are a MS in Electrical Engineering or Physics with 5 to 15 years of applicable experience and/or an equivalent combination of education, experience, and specific training. Incumbent must have a strong background and a demonstrated track record of innovative and significant contributions in RF, microwaves, and accelerator physics/engineering; and have a working knowledge in at least two of the following areas: receiver design, electro-optical engineering, control systems, or signal processing. While the candidate must be able to work independently under minimum supervision, the ability to work and communicate effectively in multidisciplinary teams of physicists, engineers, and technicians is of prime importance. For prompt consideration, please send resume with salary history to:

Jefferson Lab  
ATTN: Employment Manager  
12000 Jefferson Avenue,  
Newport News, VA 23606

Specify position number and job title when applying.

Proud to Be An Equal Opportunity, Affirmative Action Employer.

Sponsored by: Force Computers,



**DON'T MISS**  
**SysComms '98**

25-26 March '98

CERN, Geneva, Switzerland

EXHIBITION AND TECHNICAL CONFERENCE

Europe's Premier Real-time & Embedded Systems Event

Organised by VITA Europe, ESONE, GroupIPC, ESOFIA Europe and PICMG Europe and hosted by CERN - the world famous particle physics laboratory - SysComms '98 offers a packed multi-track technical conference featuring top speakers from research and industry. SysComms '98 covers all aspects of embedded and real-time systems including data acquisition, process control, software and hardware architectures, bus systems and communications including:

- Bus system developments: VME64 Extensions, Compact PCI
- Sub-system buses: Raceway, Myrinet, P2CI
- High-speed interconnects
- Operating systems - real-time, hard and soft
- The impact of PC technology - PCI, PMC, Windows NT
- Diagnostic tools, hardware and software
- Standard APIs
- VMEbus for Physics

**TWO DAY EXHIBITION ●**  
**& TECHNICAL CONFERENCE ●**  
**WITH TUTORIAL SESSIONS ●**  
**FULL COMPANION PROGRAMME ●**  
**GALA DINNER ●**  
**GUIDED TOURS OF CERN ●**

**REGISTER NOW!**

Find out more on our Web Site at:  
<http://www.cern.ch/ESONE/Syscomms98/>



**SysComms INTERNATIONAL**

1 West Street, Titchfield, Hants. PO14 4DH. UK  
Tel: +44 (0) 1329 846166, Fax: +44 (0) 1329 512063;  
Email: [lyndsey@ghnet.demon.co.uk](mailto:lyndsey@ghnet.demon.co.uk)  
All trademarks are acknowledged; Photos by kind permission of CERN

SysComms '98 would like to thank the Director General, management and staff of CERN for their kind hospitality and invaluable assistance in the planning, hosting and organisation of this event.

Motorola Computer Group, Embedded Systems Engineering, Real Time Magazine, System and VITA Journal

INCORPORATING THE VITA EUROPE CONFERENCE AND THE ESONE EMBEDDED SYSTEMS WORKSHOP

The expertise of CERN vacuum specialist Alastair Mathewson (1940-97) was widely sought. He is seen here (centre) in the HERA ring at DESY, Hamburg, with DESY Accelerator Division Leader Dieter Trienes (back to camera) and DESY vacuum specialist Kirsten Zapfe-Düren.



He had a strong sense of humour and his loud laughter was an immediate indicator of his presence. His hospitality was legendary and many visitors remember enjoyable evenings at his home in Fredensborg north of Copenhagen. A vivid and enjoyable personality, he left a lasting impact on our field, both through his own contributions and through his influence on others.

---

**Alastair Mathewson 1940-97**

---

CERN high vacuum specialist Alastair Mathewson died on 12 October after a long, cruel illness which he endured with admirable but typical patience.

After obtaining his PhD at Aberdeen in 1967, as a St. Andrews post-doctoral fellow he studied the electrical properties of lead sulphide at low temperatures and high magnetic fields. Moving to Chalmers University of Technology, Gothenburg, Sweden, he built an ultra-high vacuum chamber for pressures below  $10^{-10}$  Torr for the study of optical properties of metal films.

With this very relevant background, he joined CERN's ISR vacuum group

in 1972, where limitations due to ion-induced pressure instabilities had made it clear that special surface studies were required. Alastair set up a surface studies laboratory and organized the glow-discharge cleaning of the 2 km ISR vacuum system. As a result of his persistent efforts, the ISR design intensity went on to be exceeded by a factor of 3. This work earned him widespread recognition. Another method he developed has become the widely applied 'CERN recipe' for chemical cleaning.

He was invited frequently to present his work and was consulted for practically all major world accelerator projects. More recently, he concentrated on the LHC vacuum system and initiated collaborations with several large laboratories around the world. The fundamental understanding of the physics and the mechanical design concept for the LHC beam screen are, to a large extent, his personal contribution.

His knowledge and guidance will be sorely missed. At his funeral, it was pointed out that as a high vacuum specialist whose expertise was widely admired and sought after, Alastair Mathewson's passing indeed leaves a void.

Two organizers of the CERN Computing School in Prague, 1997 - Carlo Vandoni of CERN, left, and François Etienne of the French CNRS - meet at the X IEE Real Time Conference in Beaune, France.

---

**Meetings**

---

The 3rd European Workshop On Low Temperature Electronics, WOLTE3, will take place in San Miniato al Todesco, Italy, from 24 - 26 June 1998. The Workshop is organised by D.V. Camin/Milan (Chairman), F.-L. Navarria/Bologna, P.G. Pelfer/Florence and G. Pessina/Milan, and is sponsored by IEEE on Electron Devices, INFN, Universities of Bologna, Florence and Milan, Regione Toscana.

The deadline for submitting a 2-page abstract is 15 December. E-mail wolte3@mi.infn.it otherwise send three paper copies to Prof. D.V. Camin, Dip. di Fisica, Via Celoria 16, I-20133 Milano; fax ++ 39 2 2392 624. <http://www.bo.infn.it/sminiato/sminiato98.html>

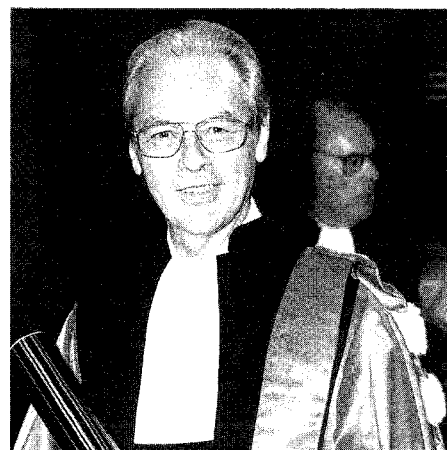

Ugo Amaldi of Milan and CERN receives the award of Doctor Honoris Causa of the University Claude Bernard Lyon 1 (see page 28).

**Seasons greetings**

**The CERN Courier wishes all its readers a good New Year.**

**RESEARCH ASSOCIATE POSITION  
Experimental High Energy Physics  
Carnegie Mellon University**

The Department of Physics at Carnegie Mellon University invites applications for a postdoctoral Research Associate position in experimental high energy physics. The individual who fills this position will work on detector development for the future CMS experiment at the LHC, in particular, the front-end anode electronics for the CMS endcap muon system. Participation in data analysis for the on-going L3 experiment at LEP will also be encouraged. The successful candidate will work both at Fermilab and at CERN. Applicants should submit a curriculum vitae and arrange to have three letters of recommendation sent directly and as soon as possible to:

Professor Thomas Ferguson  
Department of Physics  
Carnegie Mellon University  
Pittsburgh, PA 15213, USA  
(e-mail: ferguson@cmphys.phys.cmu.edu)

The vitae and recommendations can be sent either by normal or electronic mail. We will begin to consider applications on Nov. 15, 1997.

*Carnegie Mellon is an equal opportunity /  
affirmative action employer*

**UNIVERSITY OF TORONTO  
TENURE TRACK FACULTY POSITION  
DEPARTMENT OF PHYSICS**

The Department of Physics plans to make a tenure track appointment in High Energy Physics at the rank of Assistant Professor, subject to budgetary approval, with a starting date of July 1, 1998.

We seek candidates with a Ph.D. in Physics, proven or potential excellence in both research and teaching, whose research interests are in Theoretical Particle Physics. Salary will be commensurate with qualifications and experience.

Applications, including a curriculum vitae and three letters of reference should be sent to:

Professor Pekka Sinervo  
Chair  
Department of Physics  
University of Toronto  
60 St. George Street  
Toronto, Ontario ... M5S 1A7  
Canada

The deadline for the receipt of applications and letters of recommendation is December 31, 1997.

In accordance with Canadian immigration requirements, priority will be given to Canadian citizens and permanent residents of Canada. The University of Toronto is committed to employment equity and encourages applications from all qualified individuals including women, members of visible minorities, aboriginal persons, and persons with disabilities.



**University of Alberta  
Edmonton**

**Department of Physics  
Assistant Professor  
Experimental Particle Physics**

The Department of Physics invites applications for a tenure track position in experimental collider physics at the Assistant Professor level to begin July 1, 1998. Candidates must have a PhD or equivalent, and postdoctoral experience. We are looking for an individual with demonstrated ability and outstanding potential for excellence in teaching and research.

The Department of Physics has excellent support facilities to complement the research of its 36 faculty and 70 graduate students, including well equipped electronics and machine shops and experienced technical staff. Members of the department are currently collaborating on OPAL and ATLAS at CERN, HERMES at HERA, E787 at BROOKHAVEN, and E614 at TRIUMF. We expect to fill a number of tenure track positions in particle physics and other areas during the next three years.

In accordance with Canadian Immigration requirements, priority will be given to Canadian citizens and permanent residents of Canada. If suitable Canadian citizens and permanent residents cannot be found, other individuals will be considered. Applicants should submit a complete curriculum vitae, including a research proposal and a teaching profile, and arrange to have at least three confidential letters of recommendation sent on their behalf to:

J. Samson, Chair  
Department of Physics  
University of Alberta  
412 Avadh Bhatia Physics Lab  
Edmonton, Alberta T6G 2J1

Early responses are encouraged, closing date for applications is January 1, 1998.

*The University of Alberta is committed to the principle of equity in employment. As an employer we welcome diversity in the workplace and encourage applications from all qualified women and men, including Aboriginal peoples, persons with disabilities, and members of visible minorities.*

**...it makes sense.**

UNIVERSITY OF ALBERTA

# VISHAY



**ENGINEERING OUR FUTURE !**



**VISHAY ELECTRONIC COMPONENTS EUROPE**

GEHEIMRAT-ROSENTHAL-STRASSE 100 · D-95100 SELB · TEL.: (49) 9287-71 0 · FAX: (49) 9287-70 435